

# HUANUO

## Steel Desktop Stand Instruction Manual

V1.0

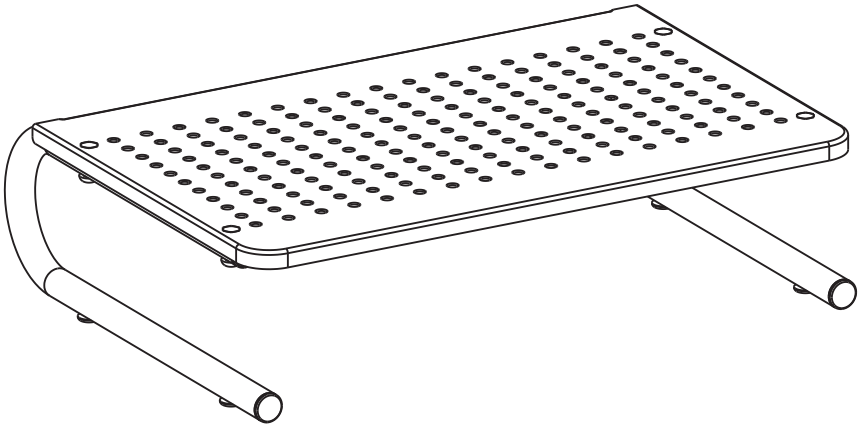

Model: HNLL2/HNLL2S/HNLLK2/HNLL2K4



Website:  
[www.huanuoav.com](http://www.huanuoav.com)

Thank you for choosing this Huanuo product! At Huanuo we strive to provide you with the best quality products and services in the industry. Please share your experience of our product with others at [www.huanuoav.com/reviews](http://www.huanuoav.com/reviews) if you are satisfied. Should you have any issues, please don't hesitate to contact us.

Technical Support:

1-800-556-0533 Mon-Fri 10am - 5pm (PST) (USA) (CAN)

Other Info:

[support@huanuoav.com](mailto:support@huanuoav.com) (US/CA)

[supporteu@huanuoav.com](mailto:supporteu@huanuoav.com) (DE/UK/FR/IT/ES/AU)

[support\\_jp@huanuoav.com](mailto:support_jp@huanuoav.com) (JP)

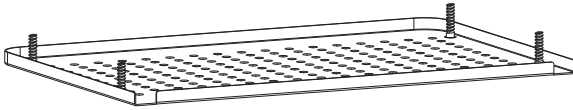

A x1

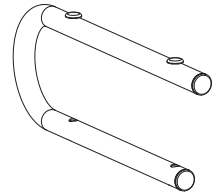

B x2



C x4



D x1

