

HUANUO

VESA Adapter Instruction Manual

V7.0(A)

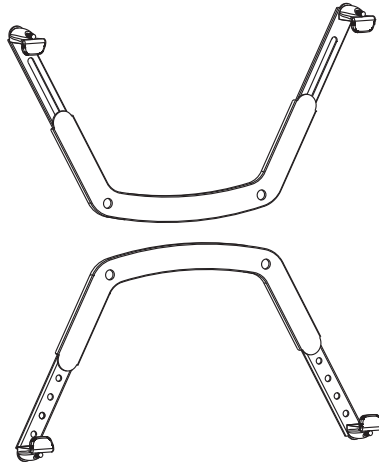

Model: HNMUA4

English	-----	01-03
Deutsch	-----	04-06
Français	-----	07-09
Español	-----	10-12
Italiano	-----	13-15
日本語	-----	16-18

Thank you for choosing this HUANUO product! At HUANUO we strive to provide you with the best quality products and services in the industry. Should you have any issues, please don't hesitate to contact us at

Technical Support:

(US/CA)1-800-556-0533 Mon-Fri 8am - 8pm(CST)

(UK)44-808-196-3874 Mon-Fri 2pm - 10pm(UTC)

Other Info:

support@huanuoav.com

support_jp@huanuoav.com(JP)

Website: www.huanuoav.com

IMPORTANT SAFETY INSTRUCTIONS

- Please read through these instructions completely before attempting installation. If you do not understand the instructions or have any concerns or questions, please contact our customer service at support@huanuoav.com.
- Check package contents against Supplied Parts and Hardware List to assure that all components were received undamaged. Do not use damaged or defective parts. If you require replacement parts, please contact our customer service at support@huanuoav.com.
- Not all parts and hardware included will be used.
- Do not use this product for any purpose or in any configuration not explicitly specified in this instruction. We hereby disclaim any liability for injury or damage arising from incorrect assembly, incorrect mounting, or incorrect use of this product.
- This product fits most monitors in the size of 17–32in.

SUPPLIED PARTS AND HARDWARE INCLUDED

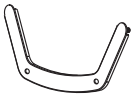

A (x2)
Bracket



B (x12)
Spacer



C (x2)
Bracket
Adaptor

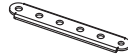

D (x2)
Bracket
Adaptor



E (x4)
Monitor
Clip



F (x4)
Soft Pad



G (x4)
M5x40mm
Bolt



H (x4)
M5x65mm
Bolt



I (x4)
M6
Nut



J (x4)
M4
Bolt



K (x6)
φ13xφ6.2xT1.5
Washer



L (x1)
M5/M6
Wrench



M (x4)
Soft Pad

STEP 1 Adaptor Assembly

STEP 1.1 Secure bracket adaptors [C] to bracket [A]

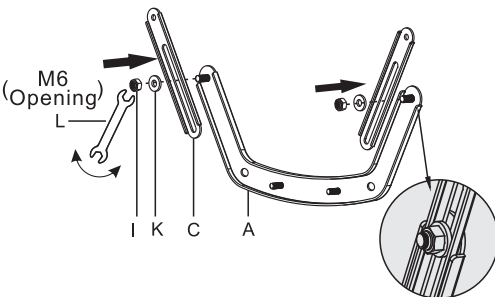

Note: Please do not over-tighten the nuts in order not to affect the length adjustment of the bracket assembly.

STEP 1.2 Secure bracket adaptors [D] to bracket [A]

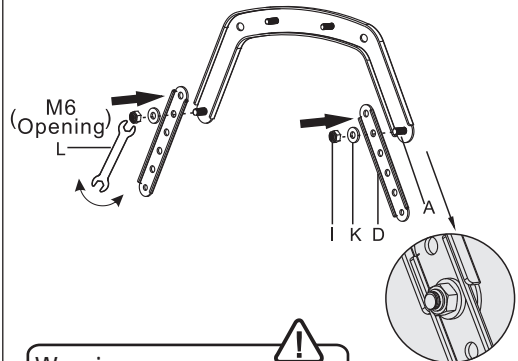

Warning:
Ensure bolts are secured firmly.

STEP 2 Parts Assembly

STEP 2.1 Peel off the protect paper of the soft pads [F], then attach them to the monitor clips [E]

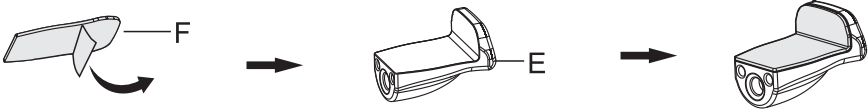

STEP 2.2 Secure the monitor clips [E] to bracket assembly

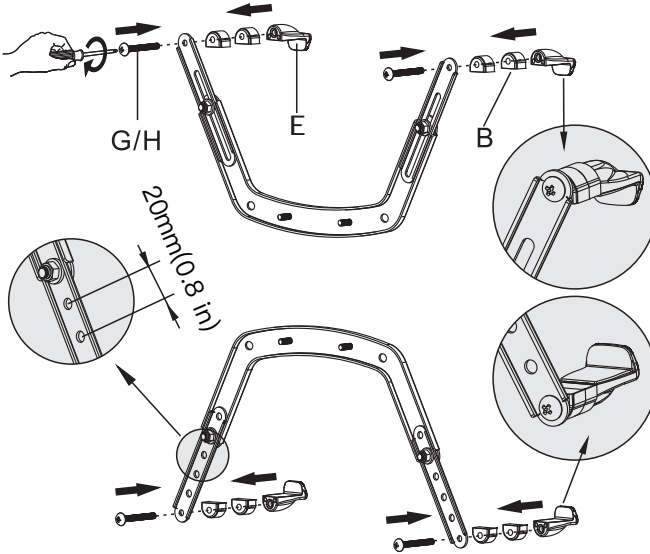

Warning:  Ensure bolts are secured firmly.

Note: Select appropriate number of spacers [B] to fit the thickness of the monitor.

Alternate Spacer Setups



STEP 3 Secure Bracket Assembly onto Monitor Plate(Not Included)

If monitor plate comes with 2 gourd-shaped holes, you need to use the 2 extra washers [K] as shown in the figure.

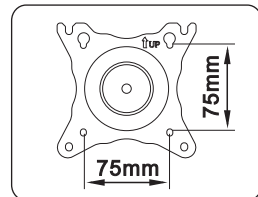
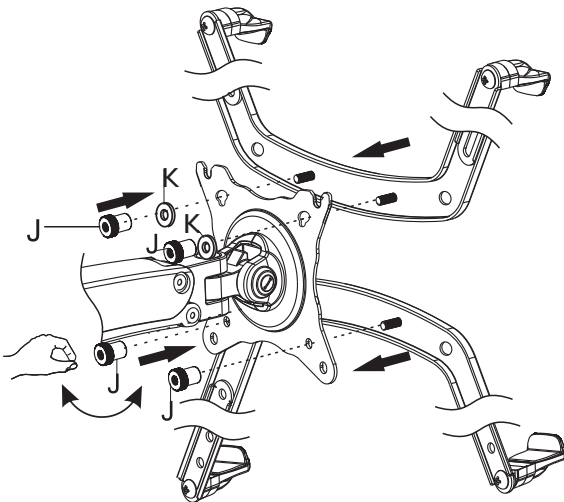

[Not Included]

Warning:  Ensure bolts are secured firmly.

Step 4 Secure Monitor to Bracket Assembly

STEP 4.1 Peel off the protect paper of the soft pads [M], then attach them to the bracket assembly

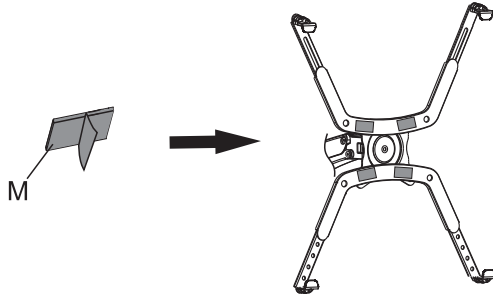

STEP 4.2 Attach the monitor to the center of the bracket assembly. Then adjust the size of the bracket assembly according to the size of monitor

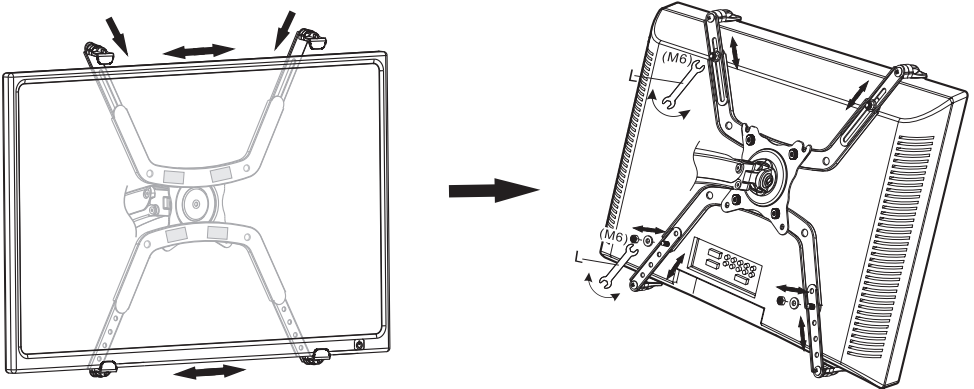

STEP 4.3 Fasten the nuts to secure the monitor to bracket assembly

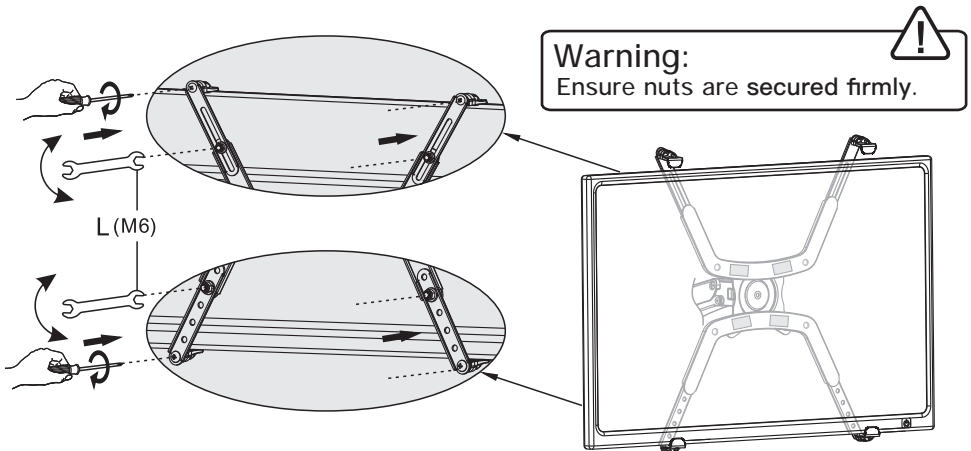

WICHTIGE SICHERHEITSANWEISUNGEN

- Bitte lesen Sie diese Anleitung vollständig durch, bevor Sie mit der Installation beginnen. Wenn Sie die Anweisungen nicht verstehen oder irgendwelche Fragen haben, wenden Sie sich bitte an den Kundendienst unter support@huanuoav.com.
- Überprüfen Sie den Packungsinhalt anhand der Liste der gelieferten Teile und der Hardware, um sicherzustellen, dass alle Komponenten unbeschädigt eingegangen sind. Verwenden Sie keine beschädigten oder defekten Teile. Falls Sie Ersatzteile benötigen, wenden Sie sich an den Kundendienst unter support@huanuoav.com.
- Es werden nicht alle enthaltenen Teile und Hardware verwendet.
- Verwenden Sie dieses Produkt nicht für einen Zweck oder in einer Konfiguration, die nicht ausdrücklich in dieser Anleitung angegeben ist. Wir lehnen hiermit jegliche Haftung für Verletzungen oder Schäden ab, die durch unsachgemäße Montage, falsche Montage oder unsachgemäße Verwendung dieses Produkts entstehen.

Mitgelieferte Teile und Hardware



A (x2)
Halterung



B (x12)
Abstandshalter



C (x2)
Halterung
Adapter

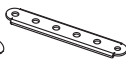

D (x2)
Halterung
Adapter



E (x4)
Monitor
Klemme



F (x4)
Weiche
Auflage



G (x4)
M5x40mm
Bolzen



H (x4)
M5x65mm
Bolzen



I (x4)
M6
Schraubenmutter



J (x4)
M4
Bolzen



K (x6)
φ13xφ6.2xT1.5
Unterlegscheibe



L (x1)
M5/M6
Schraubenschlüssel



M (x4)
Weiche
Auflage

SCHRITT 1. Adapter Montage

SCHRITT 1.1

Befestigen Sie die Halterung Adapter [C] an der Halterung [A].

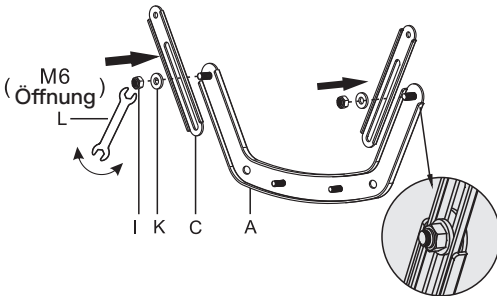

Hinweis: Ziehen Sie die Schraubenmutter nicht zu fest an, um die Längeneinstellung der Halterung nicht zu beeinträchtigen.

SCHRITT 1.2

Befestigen Sie die Halterung Adapter [D] an der Halterung [A].

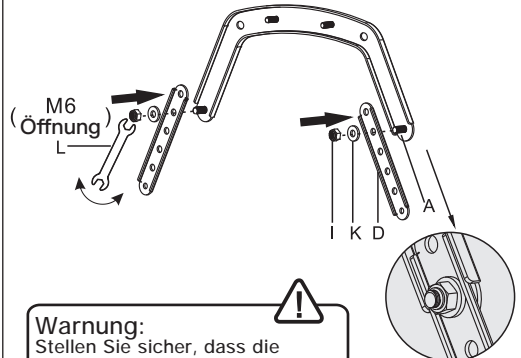

Warnung: Stellen Sie sicher, dass die Bolzen fest angezogen sind.

SCHRITT 2. Teile Montage

SCHRITT 2.1 Ziehen Sie das Schutzpapier von den Weiche Auflage [F] und befestigen Sie sie an den Monitorklemme [E].

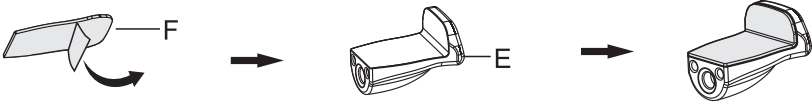

SCHRITT 2.2 Befestigen Sie die Monitor Klemme [E] an der Halterung

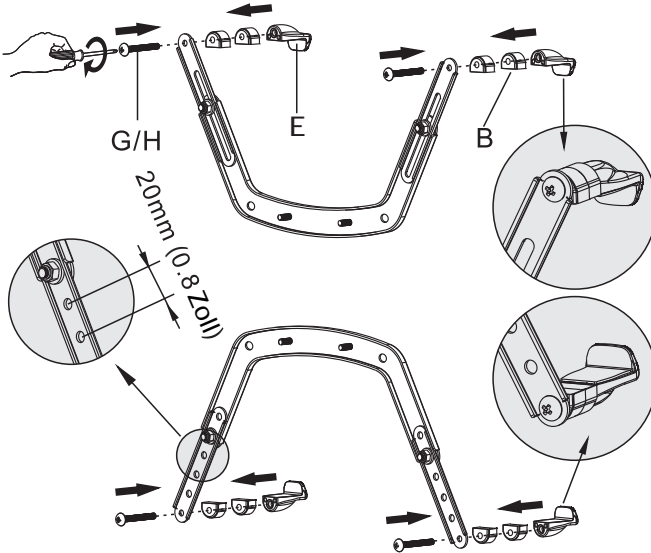

Warnung:



Stellen Sie sicher, dass die Bolzen fest angezogen sind.

Hinweis:

Wählen Sie die entsprechende Anzahl von Abstandshaltern [B], um sie an die Dicke des Monitors anzupassen.

Alternative Abstandshalter Einstellungen



SCHRITT 3. Befestigen Sie die Halterung an der Monitorplatte (nicht im Lieferumfang enthalten)

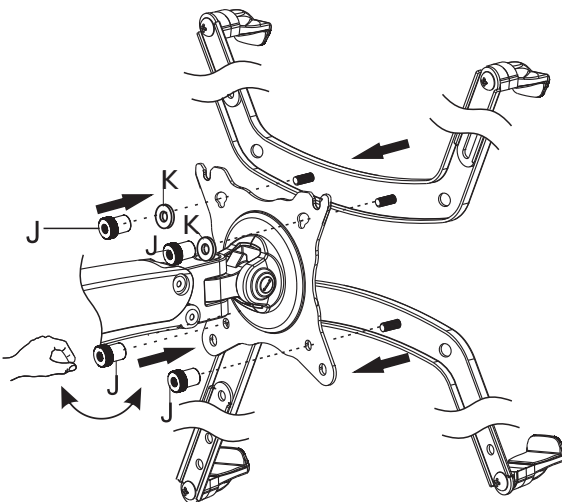

Wenn die Monitorplatte mit 2 kürbisförmigen Löchern ausgestattet ist, müssen Sie die 2 zusätzlichen Unterlegscheiben [K] verwenden, wie in der Abbildung gezeigt.

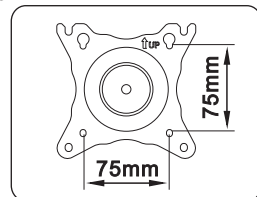

[Nicht im Lieferumfang enthalten]

Warnung:



Stellen Sie sicher, dass die Bolzen fest angezogen sind.

SCHRITT 4. Befestigen Sie den Monitor an der Halterung

SCHRITT 4.1 Ziehen Sie das Schutzpapier von den Weichpads [M] ab und bringen Sie sie an der Halterung an.

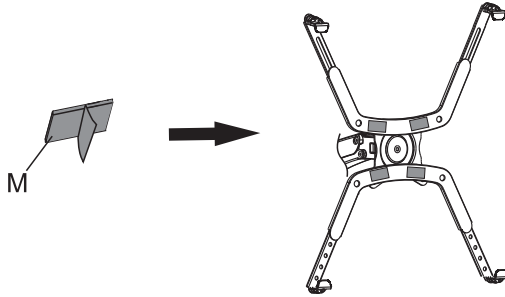

SCHRITT 4.2 Befestigen Sie den Monitor in der Mitte der Halterung. Dann passen Sie die Größe der Halterung an die Größe von an Monitor

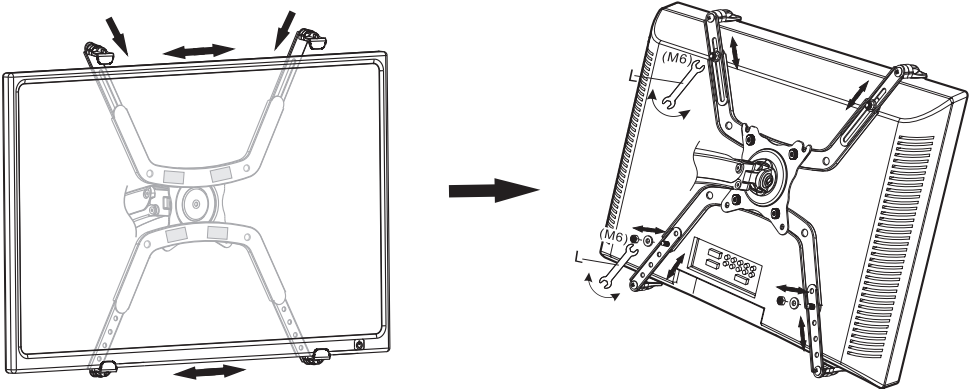

SCHRITT 4.3 Ziehen Sie die Schraubenmuttern an, um den Monitor an der Halterung zu befestigen

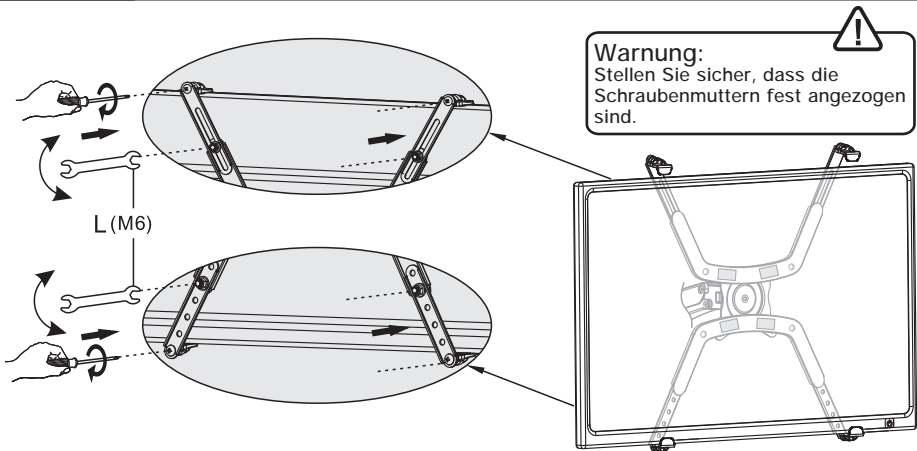

INSTRUCTIONS DE SÉCURITÉ IMPORTANTES

- Veuillez lire complètement ces instructions avant de tenter l'installation. Si vous ne comprenez pas les instructions ou avez des préoccupations ou des questions, veuillez contacter le service de clientèle à support@huanuoav.com.
- Vérifiez le contenu de l'emballage selon la Liste des Pièces et du Matériel Fournis pour vous assurer que tous les composants n'ont pas été endommagés. N'utilisez pas de pièces endommagées ou défectueuses. Si vous avez besoin de pièces de rechange, contactez le service à la clientèle à support@huanuoav.com.
- Les pièces et le matériel inclus ne seront pas tous utilisés.
- N'utilisez ce produit à aucune but ni dans aucune situation non explicitement spécifiés dans cette instruction. Nous déclinons toute la responsabilité pour les blessures ou les dommages résultant d'un assemblage incorrect, d'un montage incorrect ou d'une utilisation incorrecte de ce produit.
- Ce produit s'adapte à la plupart de moniteurs d'une taille de 17 pouces à 32 pouces.

PIÈCES ET MATÉRIEL FOURNIS ET INCLUS



A (x2)
Support



B (x12)
Entretoise



C (x2)
Adaptateur de
Support

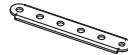

D (x2)
Adaptateur de
Support



E (x4)
Clip de
Moniteur



F (x4)
Soussinet
Souple



G (x4)
M5x40mm
Boulon



H (x4)
M5x65mm
Boulon



I (x4)
M6
Écrou



J (x4)
M4
Boulon



K (x6)
φ13xφ6.2xT1.5
Rondelle



L (x1)
M5/M6
Clé



M (x4)
Soussinet
Souple

Étape 1 Assemblage d'Adaptateur

Étape 1.1

Sécuriser les adaptateurs de support [C] sur le support [A]

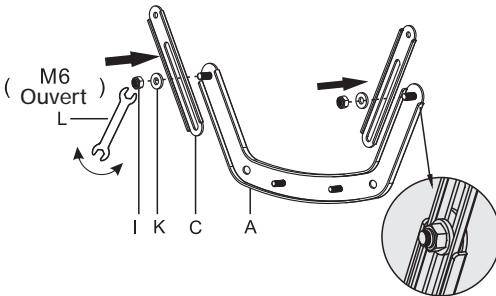

Remarque : Veuillez ne pas trop serrer les écrous pour ne pas affecter le réglage de longueur de l'assemblage de support.

Étape 1.2

Sécuriser les adaptateurs de support [D] sur le support [A]

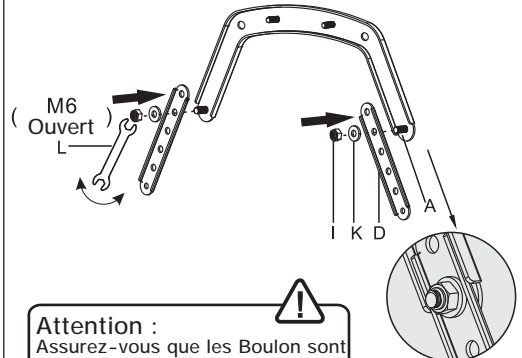

Attention : Assurez-vous que les Boulon sont bien fixées.

Étape 2 Assemblage de Pièces

Étape 2.1 Décollez le papier de protection des coussinets souples [F], puis fixez-les aux clips du moniteur [E]

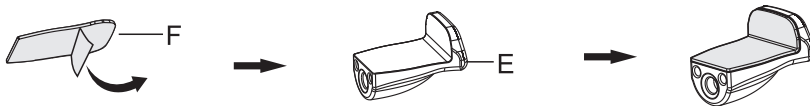

Étape 2.2 Sécuriser les clips de moniteur [E] sur l'assemblage de support

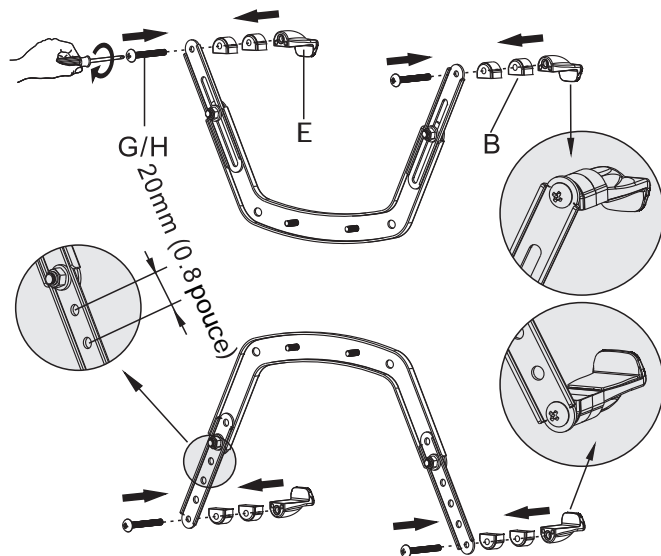

Attention :



Assurez-vous que les Boulon sont bien fixées.

Remarque :

Sélectionnez un nombre approprié d'entretoises [B] pour régler l'épaisseur du support.

Configurations d'entretoises alternatives



Étape 3 Sécuriser l'Assemblage de Support sur la Plaque de Moniteur (Non Inclusive)

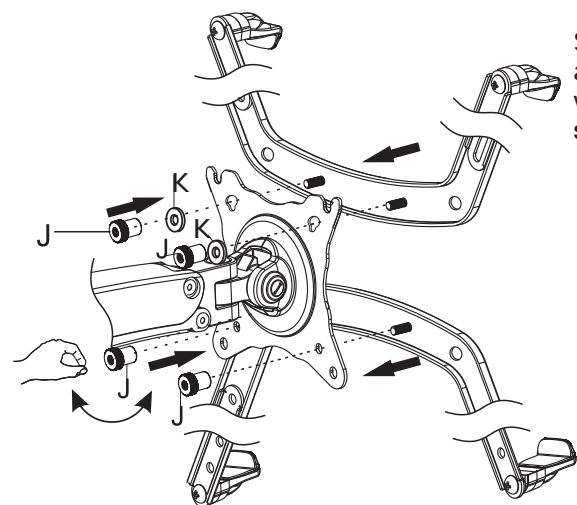

Si la plaque de moniteur est livrée avec 2 trous en forme de gourde, vous devez utiliser les 2 rondelles supplémentaires [K], voir la figure.

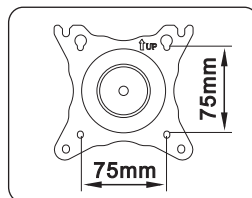

[Non Inclusive]

Attention :



Assurez-vous que les Boulon sont bien fixées.

Étape 4 Sécourir le Moniteur sur l'Assemblage de Support

Étape 4.1 Décollez le papier de protection des coussinets souples [M], puis fixez-les à l'assemblage de support

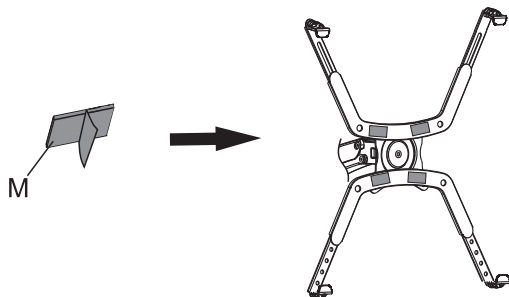

Étape 4.2 Attacher le moniteur au centre de l'assemblage de support. Puis régler la taille de l'assemblage de support selon la taille du moniteur

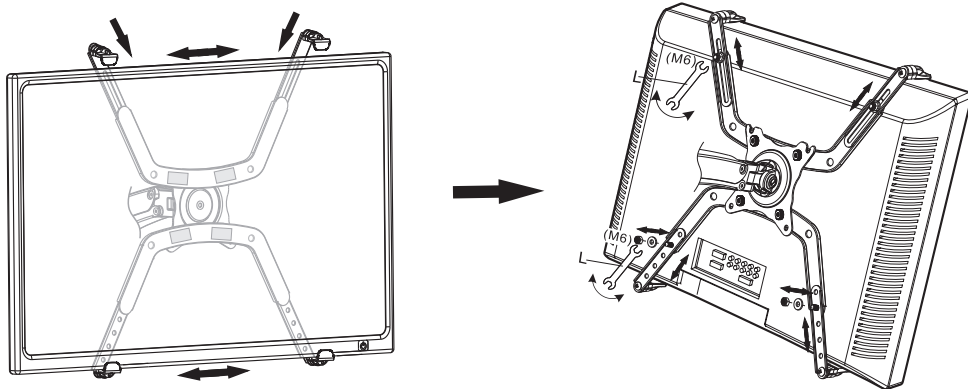

Étape 4.3 Serrer les écrous pour sécuriser le moniteur sur l'assemblage de support

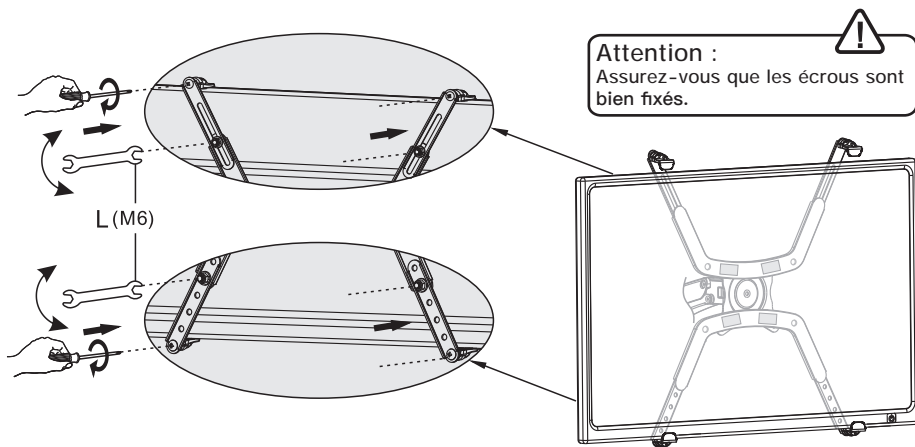

INSTRUCCIONES IMPORTANTES DE SEGURIDAD

- Leer completamente estas instrucciones antes de intentar la instalación. Si no comprende las instrucciones o tiene alguna inquietud o duda, por favor comuníquese con el servicio al cliente en support@huanuoav.com.
- Chequear el contenido del paquete según Lista de Piezas y Hardware Suministrados para asegurarse de que todos los componentes se hayan recibido sin daños. No utilice piezas dañadas o defectuosas. Si requiere piezas de repuesto, por favor comuníquese con el servicio al cliente en support@huanuoav.com.
- No hace falta utilizar todas las piezas y hardware incluidos.
- No utilice este producto para ningún propósito ni en ninguna configuración que no esté explícitamente especificada en estas instrucciones. Por la presente, renunciamos a cualquier responsabilidad por lesiones o daños derivados del montaje incorrecto, o uso inadecuado de este producto.
- Este producto se adapta a la mayoría de los monitores de 17–32 pulg.

PIEZAS SUMINISTRADAS Y HARDWARE INCLUIDO



A (x2)
Soporte



B (x12)
Espaciador



C (x2)
Adaptador de Soporte

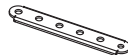

D (x2)
Adaptador de Soporte



E (x4)
Clip de Monitor



F (x4)
Almohadilla Suave



G (x4)
M5x40mm
c



H (x4)
M5x65mm
Pernos



I (x4)
M6
Tuerca



J (x4)
M4
Pernos



K (x6)
 $\phi 13 \times \phi 6.2 \times T1.5$
Arandela



L (x1)
M5/M6
Llave



M (x4)
Almohadilla Suave

PASO 1 Montaje de Adaptador

PASO 1.1 Asegurar los adaptadores de soporte [C] al soporte [A]

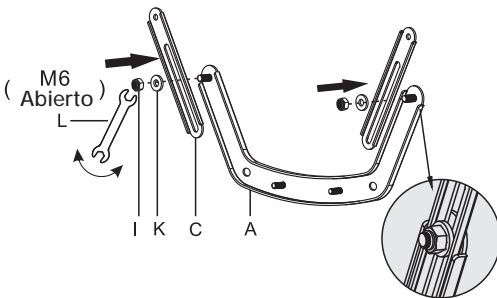

Nota: Por favor no apriete demasiado las tuercas para no afectar el ajuste de longitud del conjunto de soporte.

PASO 1.2 Asegurar los adaptadores de soporte [D] al soporte [A]

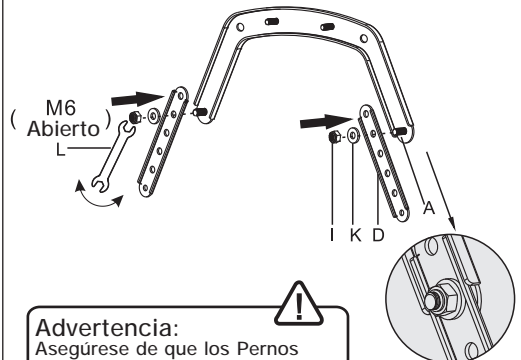

Advertencia:
Asegúrese de que los Pernos estén asegurados firmemente.

PASO 2 Montaje de Piezas

PASO 2.1 Despegar el papel protector de las almohadillas suaves [F], luego fijarlas a los clips del monitor [E]

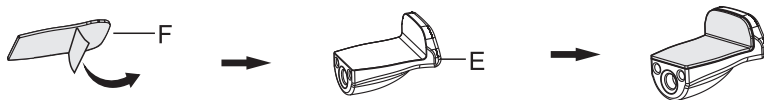

PASO 2.2 Asegurar los clips del monitor [E] al conjunto de soporte

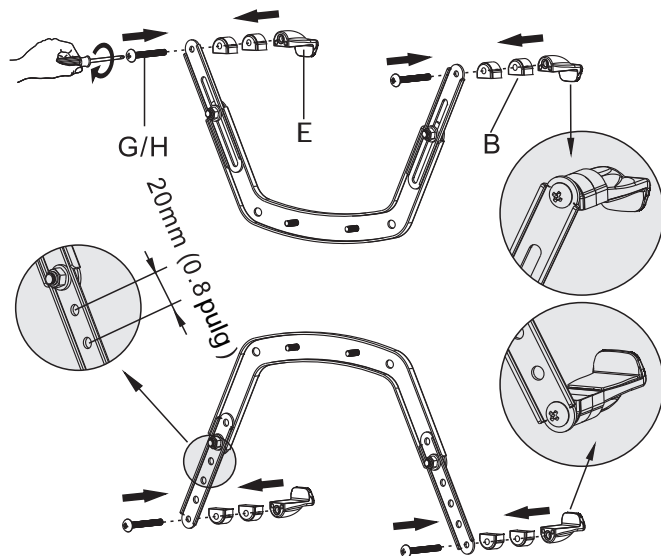

Advertencia:  Asegúrese de que los Pernos estén asegurados firmemente.

Nota: Seleccionar número apropiado de los espaciadores [B] para adaptarse al grosor del monitor.

Configuraciones Alternativas de Espaciadores



PASO 3 Asegurar el Conjunto de Soporte sobre la Placa de Monitor (No Incluida)

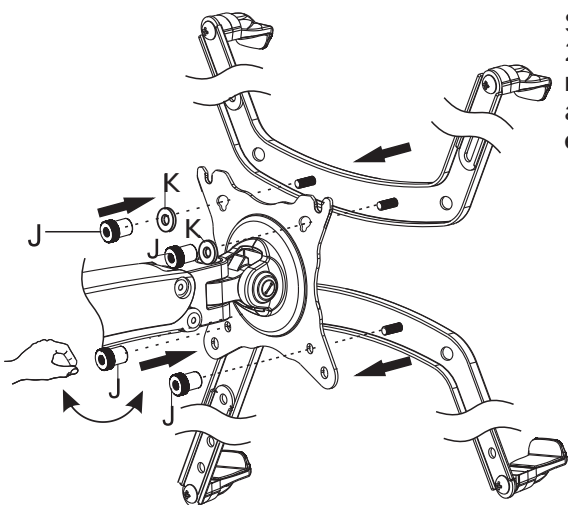

Si la placa del monitor viene con 2 agujeros en forma de calabaza, necesita usar las 2 arandelas adicionales [K] como se muestra en la figura.

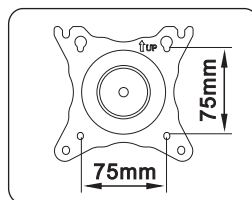

[No Incluida]

Advertencia:  Asegúrese de que los Pernos estén asegurados firmemente.

Paso 4 Asegurar el Monitor al Conjunto de Soporte

PASO 4.1 Despegar el papel protector de las almohadillas blandas [M], luego fijarlas al conjunto del soporte

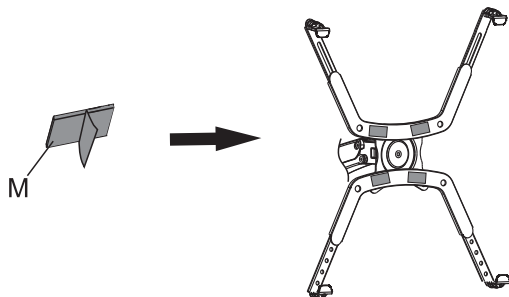

PASO 4.2 Fijar el monitor al centro del conjunto de soporte. Después ajustar el tamaño del conjunto de soporte según lo del monitor.

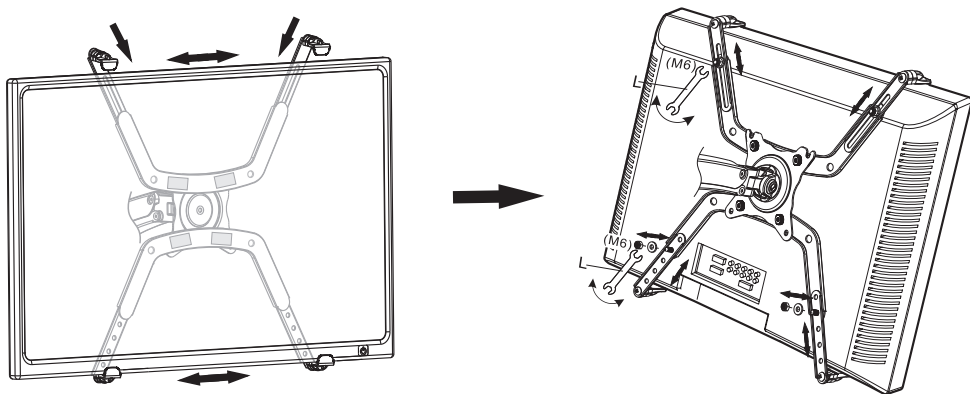

PASO 4.3 Apretar las tuercas para asegurar el monitor al conjunto de soporte

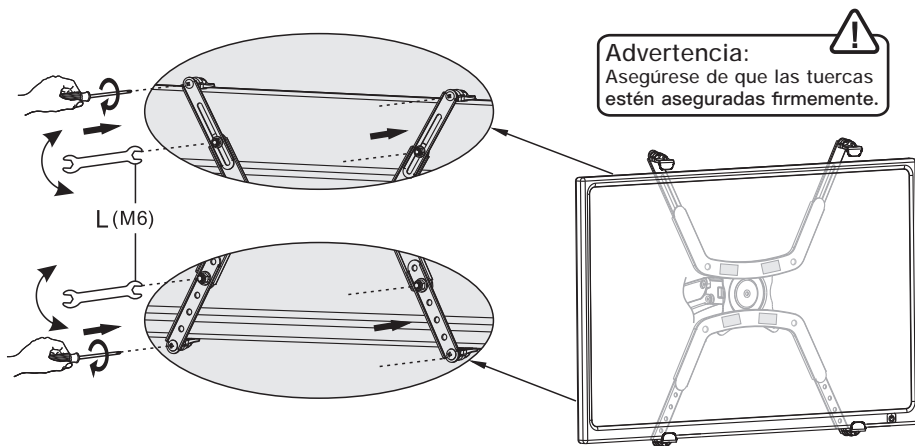

ISTRUZIONI IMPORTANTI DI SICUREZZA

- Leggere attentamente queste istruzioni prima di tentare l'installazione. Se non capire le istruzioni o avere dubbi o domande, contattare il servizio clienti all'indirizzo support@huanuoav.com.
- Verificare il contenuto della confezione con l'elenco delle parti in dotazione e dell'hardware per assicurarsi che tutti i componenti siano stati ricevuti integri. Non utilizzare parti danneggiate o difettose. Se sono necessari pezzi di ricambio, contattare il servizio clienti all'indirizzo support@huanuoav.com.
- Non verranno utilizzati tutti i componenti e l'hardware inclusi.
- Non utilizzare questo prodotto per nessuno scopo o in qualsiasi configurazione non esplicitamente specificata in queste istruzioni. Decliniamo ogni responsabilità per lesioni o danni derivanti da un montaggio errato o un uso errato di questo prodotto.
- Questo prodotto si adatta alla maggior parte dei monitor a dimensioni di 17 pollici–32 pollici

PARTI FORNITE E HARDWARE INCLUSI



A (x2)
staffa



B (x12)
distanziatore



C (x2)
Adattatore di
staffa

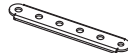

D (x2)
Adattatore di
staffa



E (x4)
Clip di
monitor



F (x4)
Cuscinetti
morbidi



G (x4)
M5x40mm
bullone



H (x4)
M5x65mm
bullone



I (x4)
M6
dado



J (x4)
M4
bullone



K (x6)
φ13xφ6.2xT1.5
rondella



L (x1)
M5/M6
Chiave inglese



M (x4)
Cuscinetti
morbidi

PASSO 1 Assemblaggio dell'adattatore

PASSO 1.1

Fissare gli adattatori della staffa [C] alla staffa [A]

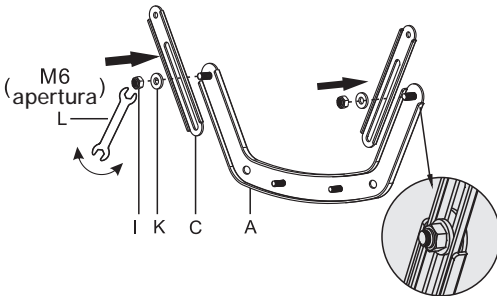

PASSO 1.2

Fissare gli adattatori della staffa [D] alla staffa [A]

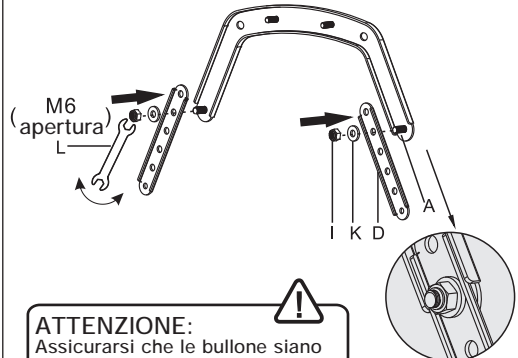

ATTENZIONE:
Assicurarsi che le bullone siano fissate fermamente.

Nota: non stringere eccessivamente i dadi per non influire sulla regolazione della lunghezza del gruppo staffa

PASSO 2 Assemblaggio delle parti

PASSO 2.1 Staccare la carta protettiva dei cuscinetti morbidi [F], e poi attaccarli alle clip del monitor [E]

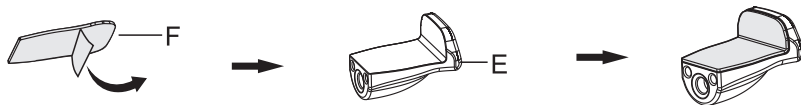

PASSO 2.2 Fissare le clip del monitor [E] al gruppo di staffa

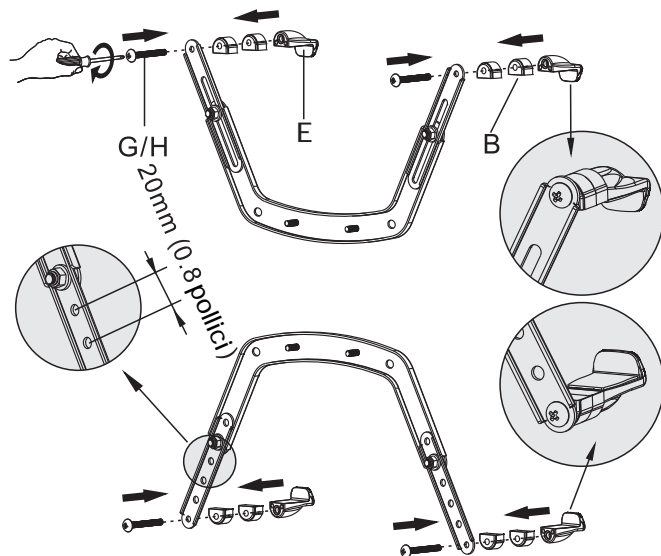

Avvertimento:



Assicurarsi che le bullone siano fissate fermamente.

Nota:

Selezionare il numero appropriato di distanziatori [B] per adattarsi allo spessore del monitor.

configurazioni di spazio alternativo



PASSO 3 Fissare il gruppo di staffa sulla piastra del monitor (non inclusa)

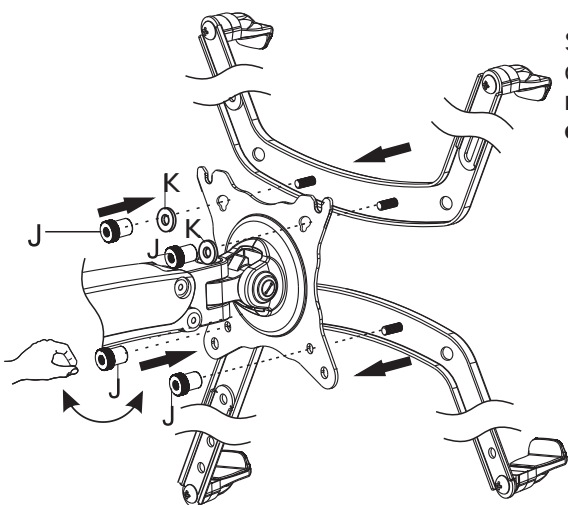

Se la piastra del monitor è dotata di 2 fori a forma di zucca, è necessario utilizzare le 2 rondelle extra [K] come mostrato in figura.

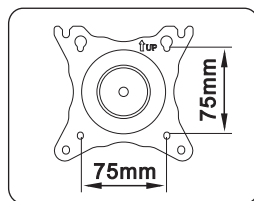

[Non incluso]



ATTENZIONE:

Assicurarsi che le bullone siano fissate fermamente.

Passo 4 Fissare il monitor al gruppo di staffa

PASSO 4.1 Staccare la carta protettiva dei cuscinetti morbidi [M], e poi fissarli al gruppo di staffa

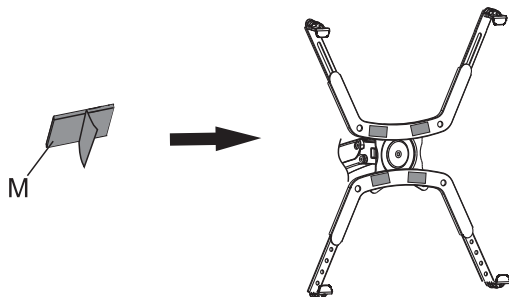

PASSO 4.2 Collegare il monitor al centro del gruppo di staffa. E poi regolare le dimensioni del gruppo di staffa in base alle dimensioni del monitor

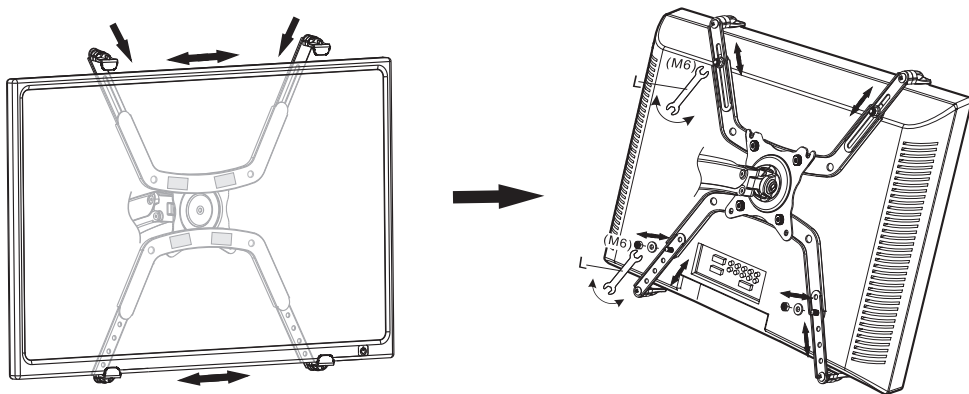

PASSO 4.3 Fissare i dadi per fissare il monitor al gruppo di staffa

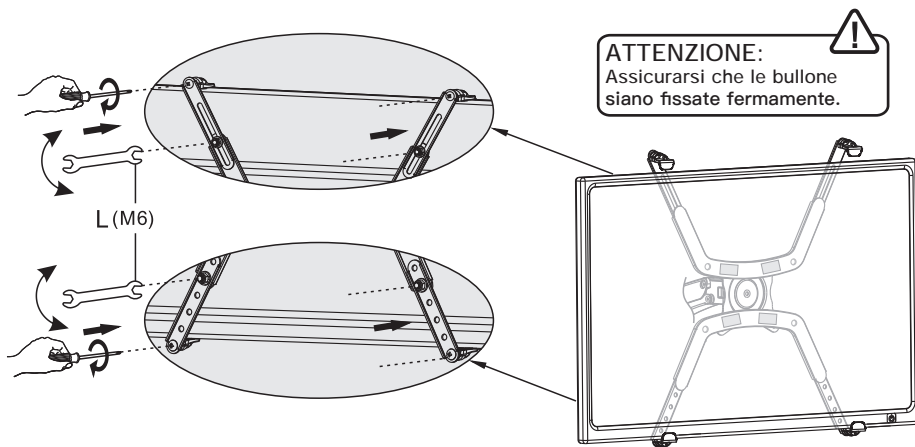

安全上のご注意

•ご使用前に、この取扱説明書をよくお読みになり、正しくお使いください。取扱説明書に何かご不明な点がございましたら、必ず、販売者や工事専門業者に連絡してください。

お問い合わせ先: support_jp@huanuoav.com.

•組み立てる前に、すべての部品が揃っており、破損してないことを確認してください。足りない部品又は破損している部品のある場合は、当社に連絡してください。

お問い合わせ先: support_jp@huanuoav.com.

•付属の部品をすべて使用するわけではありません。

•設置の際は取扱説明書に記載される以外の使用目的で使用しないでください。取り付け不備や、取り扱い不備による事故や損傷については、当社では一切の責任を負いません。

•当商品は17~32インチのモニターに対応しています。

同梱品一覧



A (x2)
ブラケット



B (x12)
スペーサー



C (x2)
ブラケットアダプター

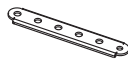

D (x2)
ブラケットアダプター



E (x4)
モニタークリップ



F (x4)
パッド



G (x4)
M5x40mm
ボルト



H (x4)
M5x65mm
ボルト



I (x4)
M6
ナット



J (x4)
M4
ボルト



K (x6)
φ13xφ6.2xT1.5
ワッシャー



L (x1)
M5/M6
レンチ



M (x4)
パッド

手順1 アダプターを組み立てる

手順1.1 アダプター[A]にブラケットアダプター[C]を取り付ける

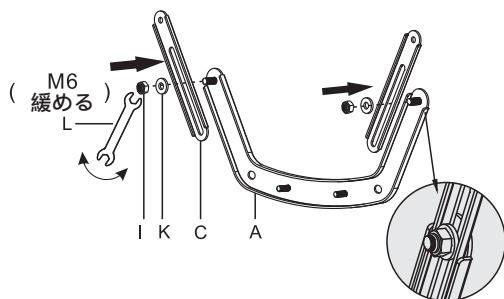

ご注意: ブラケットの長さをうまく調節するために、ナットを締め過ぎないでください。

手順1.2 アダプター[A]にブラケットアダプター[D]を取り付ける

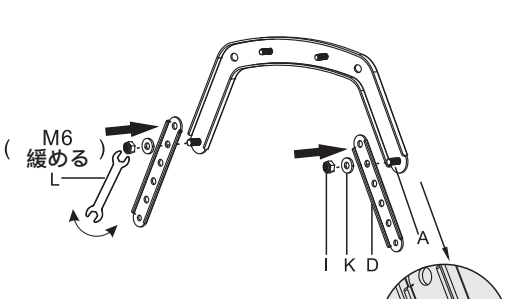

警告:
ボルトをしっかり締めることをご確保ください。

手順2 パーツを組み立てる

手順2.1 パッド[F]の保護フィルムをはがして、モニタークリップ[E]に取り付ける

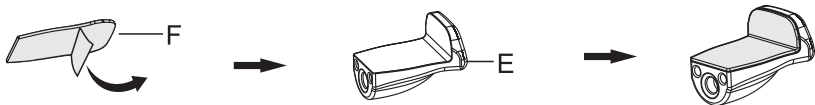

手順2.2 モニタークリップ[E]をブラケットに組み立てる

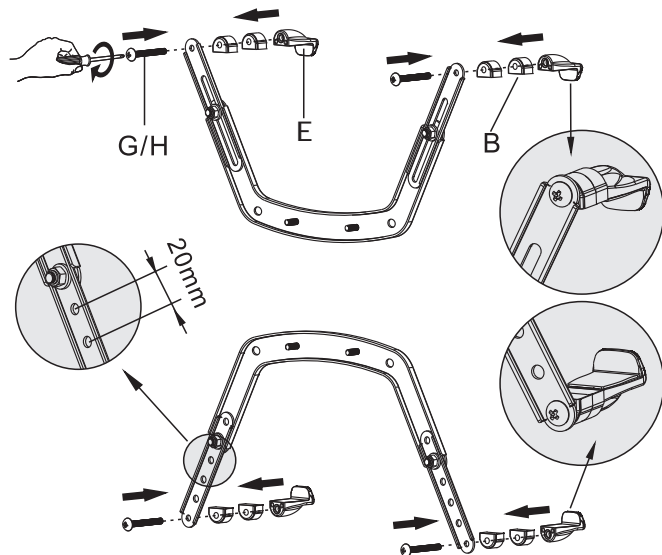

警告:

⚠
ボルトをしっかり締めることを
ご確認ください。

ご注意:

モニターの厚さに合わせて、
スペーサー[B]の使用個数をお
選びください。

スペーサーの組み合わせ方



手順3 モニタープレート（別売）にブラケットを組み立てる

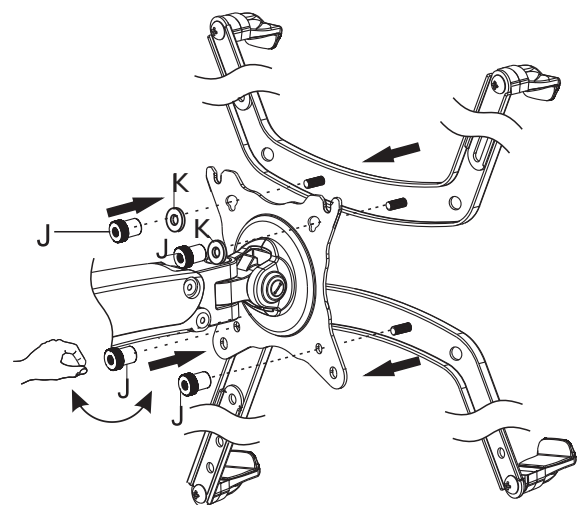

図のようにVESAプレートにひょうたん形穴がある場合は、ワッシャー[K]を使用してください。

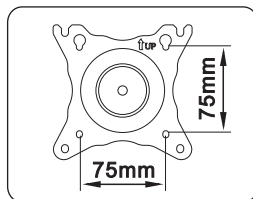

[別売]

警告:

⚠
ボルトをしっかり締めることを
ご確認ください。

手順4 ブラケットにモニターを取り付ける

手順4.1 パッド[M]の保護フィルムをはがして、図のようにブラケットに取り付ける

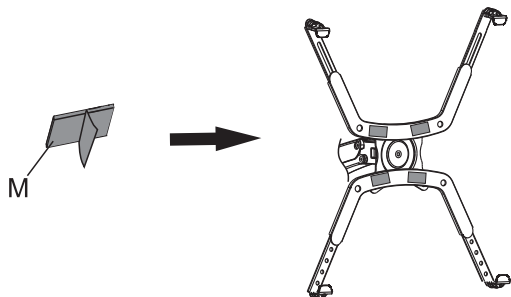

手順4.2 ブラケットの中心にモニターを取り付けてから、モニターのサイズに合わせて、ブラケットのサイズを調節する

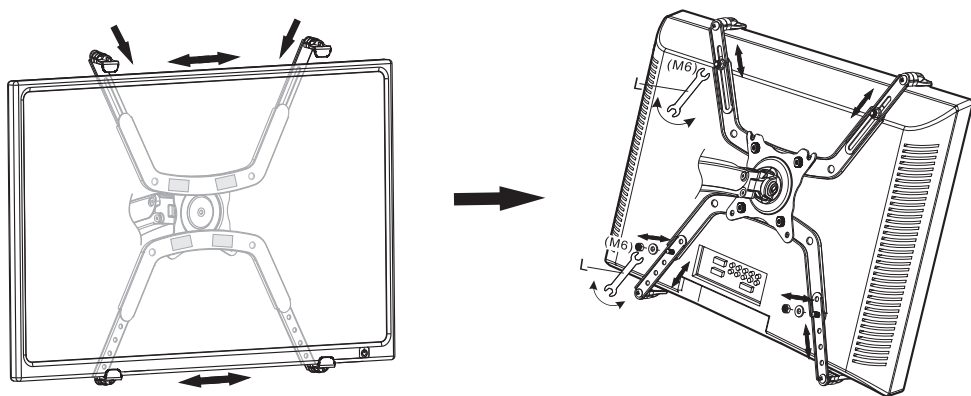

手順4.3 ナットを締め付けて、モニターをブラケットにしっかり固定する

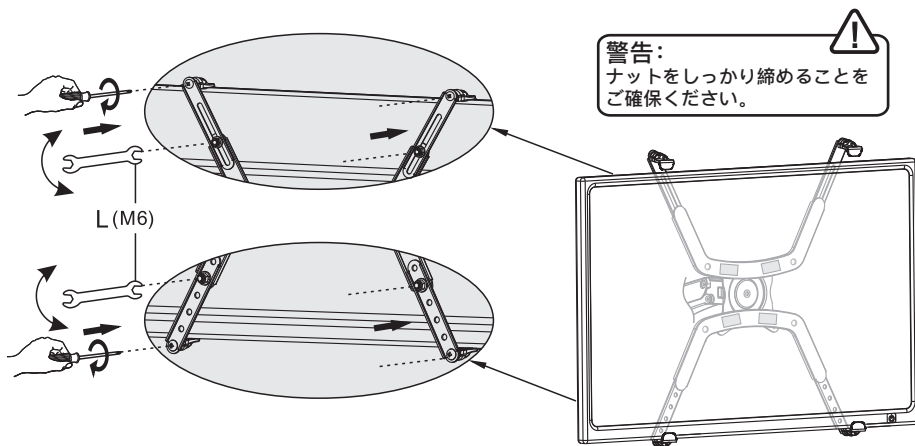

Thank you again for choosing this HUANUO product!

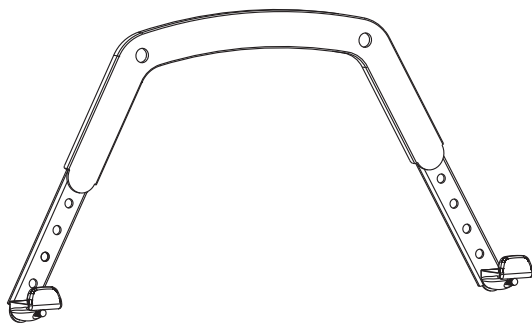
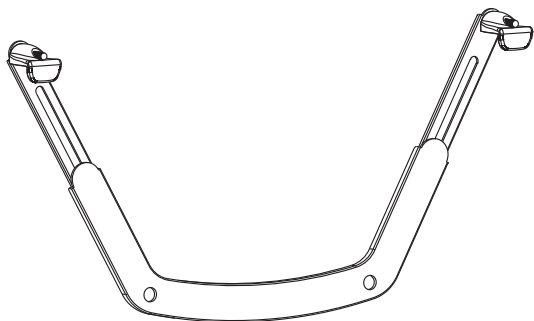

All of us at HUANUO do appreciate your product purchase. We hope that you are as happy with your product as we designing and manufacturing it for you. We strive to provide you with the best quality products and services in the industry. If you have any questions please don't hesitate to contact us at
Technical Support:

(US/CA)1-800-556-0533 Mon-Fri 8am - 8pm(CST)

(UK)44-808-196-3874 Mon-Fri 2pm - 10pm(UTC)

Other Info:

support@huanuoav.com

support_jp@huanuoav.com(JP)

Website: www.huanuoav.com