

HUANUO

OFFICE CHAIR

Instruction Manual

SILLA DE OFICINA
Manual De Instrucciones

HNOCS



Rev03



English
Español

01-08
09-16

 1-800-556-0533 (US/CA) Mon-Fri, 8am-8pm (CST)
44-808-196-3874 (UK) Mon-Fri, 2pm-10pm (UTC)

 support@huanuo.com
 www.huanuo.com



Assembly Video: Vídeo de montaje:



<https://www.huanuo.com/>

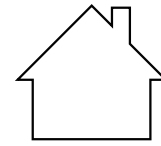
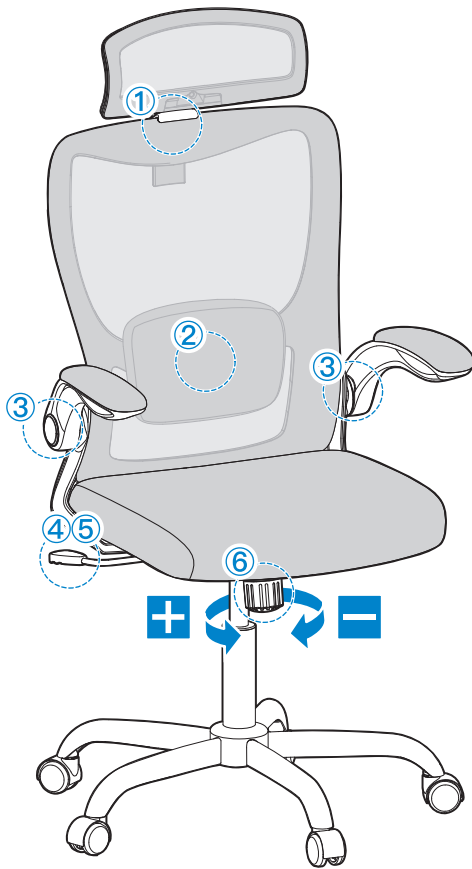

Home Office Use

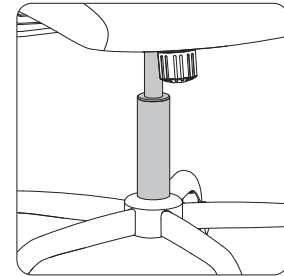

WARNING! Only trained personnel may replace or repair seat height adjustment components with energy accumulators.

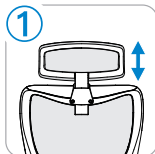

① Headrest Height Adjustment:

Grip both sides of the headrest to adjust the height.

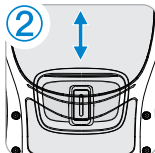

② Lumbar Support Height Adjustment:

Grip both sides of the support to adjust it up or down.

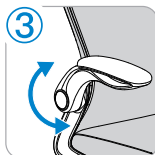

③ Folding Armrest:

Lower the armrest for support or raise it up when not in use.

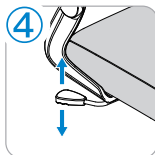

④ Seat Height Adjustment:

To raise the seat, lift your body off the chair, then pull the lever up. To lower the seat, rest your body in the chair, then pull the lever up.

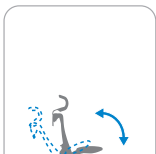

⑤ Backrest Rocking Function:

Pull the lever out to enable the rocking function. The chair will rock back and forth with the user rather than being locked in a fixed position. Return the lever to its original position to lock.

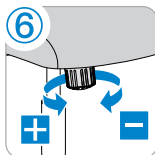

⑥ Backrest Tilt Tension Adjustment:

Turn the knob [+] or [-] to increase or decrease the rocking tension. **Tip:** Tension can be adjusted to suit a particular weight. Increase tension for heavier weight and decrease tension for lighter weight.

Missing Parts?



support@huanuo.com

Step 1 Supplied Parts and Hardware

01 x 5



Leg

02 x 1

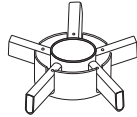

Leg Connector with
Decorative Cover

03 x 5



Caster

A x 5

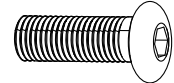

M6 x 15mm
Bolt

E x 1

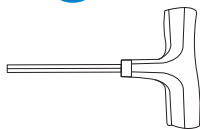

Allen Key

Step 2 Supplied Parts and Hardware

04 x 1

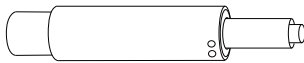

Gas Lift Cylinder

Step 3 Supplied Parts and Hardware

05 x 1

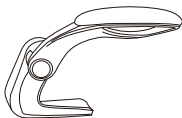

Right Armrest

06 x 1



Left Armrest

07 x 1



Backrest

B x 4

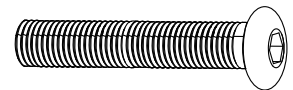

M6 x 30mm
Bolt

E x 1

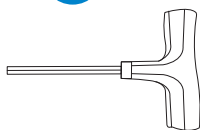

Allen Key

Step 4 Supplied Parts and Hardware

08 x 1

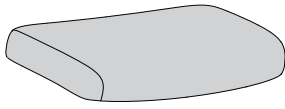

Seat

B x 4

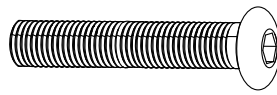

M6 x 30mm Bolt

E x 1

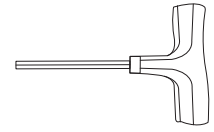

Allen Key

Step 5 Supplied Parts and Hardware

09 x 1

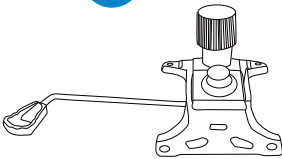

Lift Mechanism

C x 4

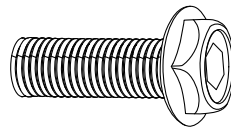

M8 x 20mm Bolt

E x 1

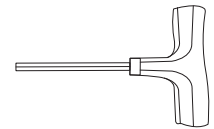

Allen Key

Step 7 Supplied Parts and Hardware

10 x 1

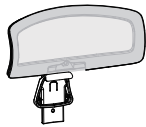

Headrest

D x 2

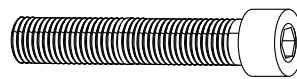

M6 x 30mm Bolt

E x 1

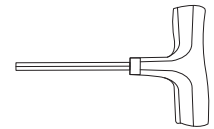

Allen Key

Step 1 Assembling the Chair Legs and Casters

Slide the legs [01] onto the leg connector [02a], then secure with bolts [A].

Remove decorative cover and keep for Step 2.

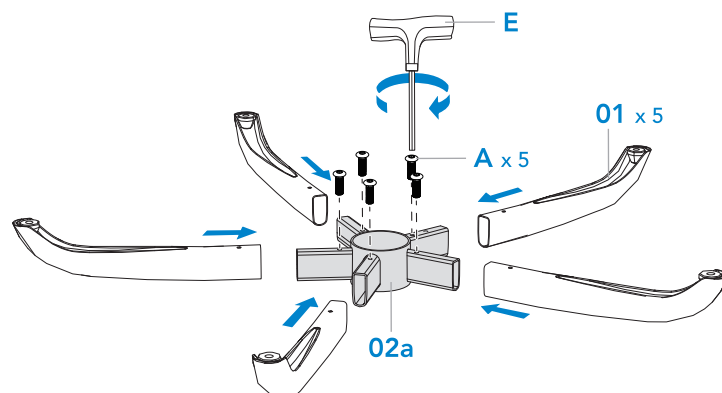
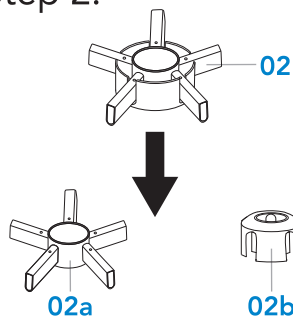

Press the casters [03] firmly into the holes on the legs.

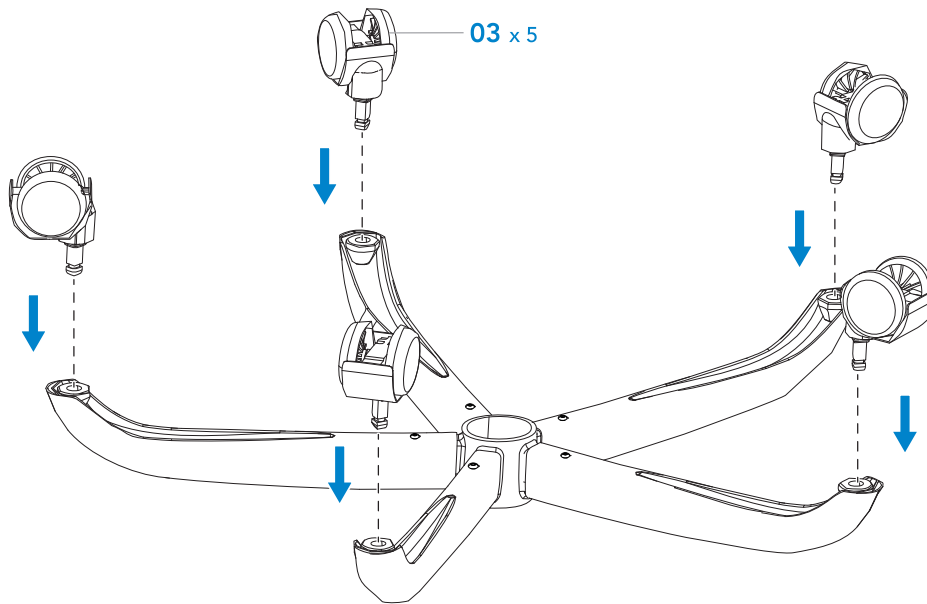

Step 2 Assembling the Chair Base

Flip over the assembled base. Attach the decorative cover [02b], then press the gas lift cylinder [04] into the leg connector.

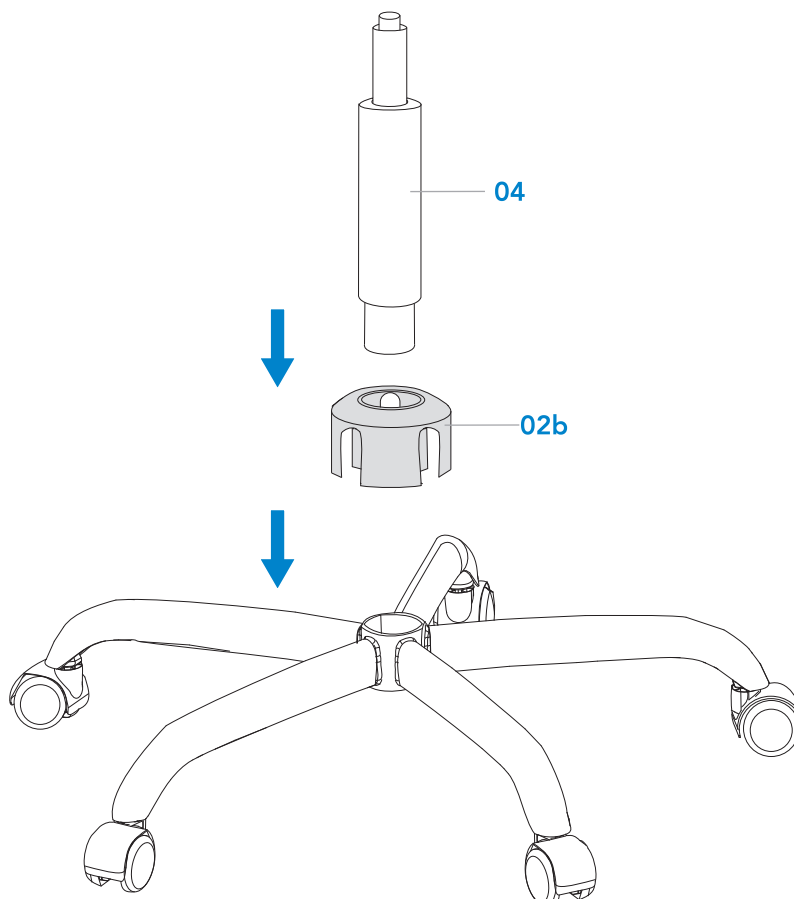

Step 3

Assembling the Armrests and Backrest

3-1 Align the holes on the right armrest [05] with the holes on the backrest [07], then secure with bolts [B].

NOTE: Tighten bolts [B] into holes by 30%. Do not fully tighten bolts [B] until Step 4 is finished.

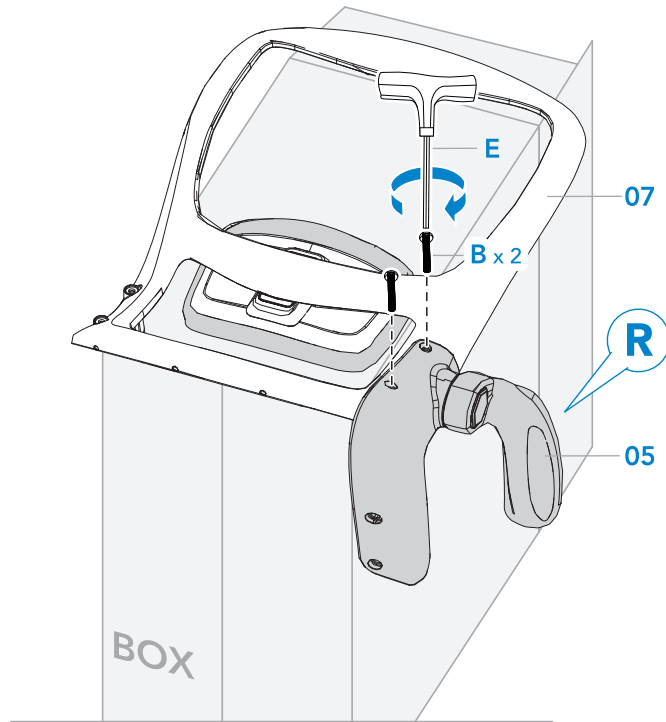

3-2 Attach the other side in reference to Step 3-1.

NOTE: Do not fully tighten bolts [B] until Step 4 is finished.

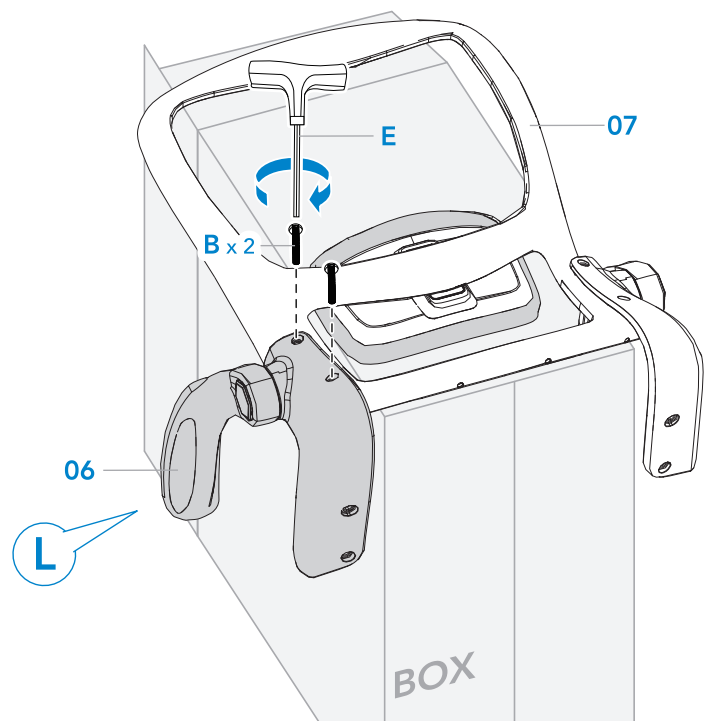

Step 4 Attaching the Seat

Attach the seat [08] to the assembled armrests with bolts [B].

NOTE: Remember to tighten all the bolts [B] in this step.

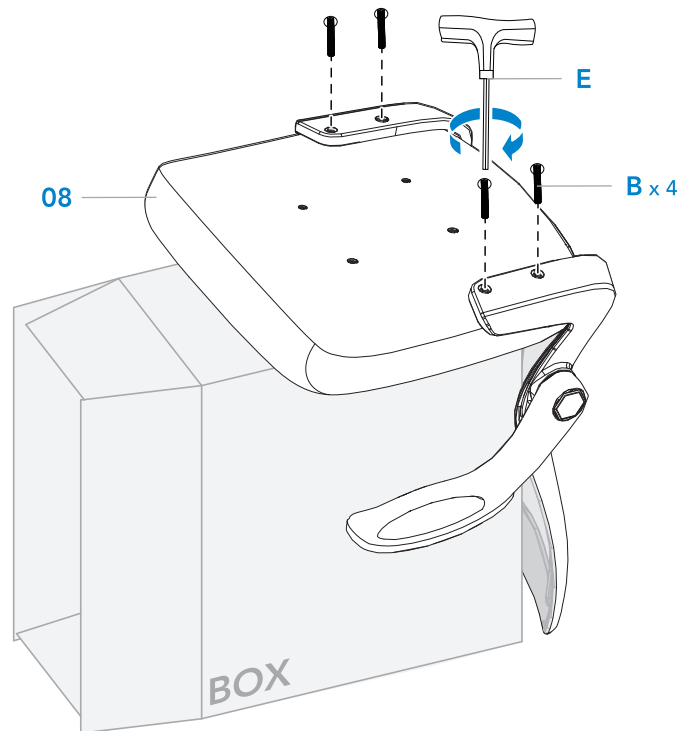

Step 5 Attaching the Lift Mechanism

Attach the lift mechanism [09] to the seat [08] with bolts [C].

NOTE:  Please note the position of the lever in this step.

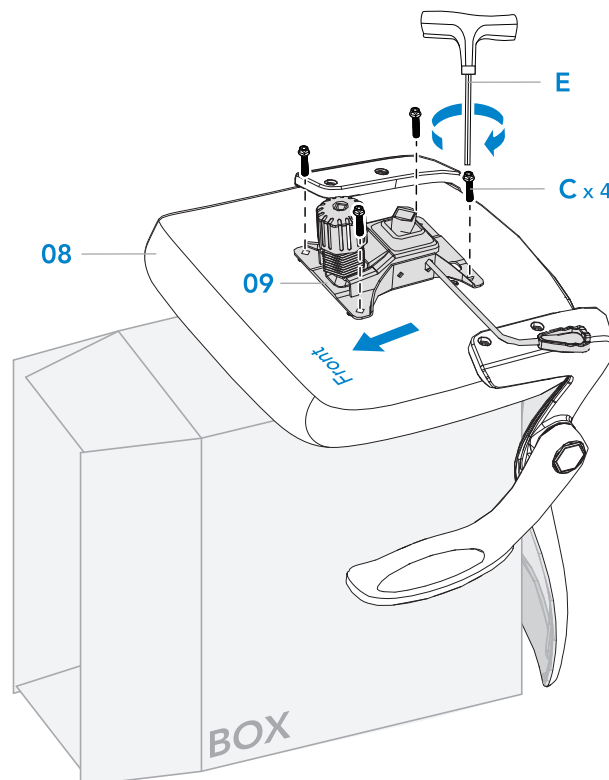

Step 6 Attaching the Chair to the Base

Align the hole underneath the chair with the gas lift cylinder [04]. Press the seat down to secure the chair to the base.

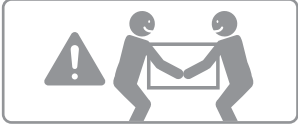

HEAVY! You may need assistance with this step.

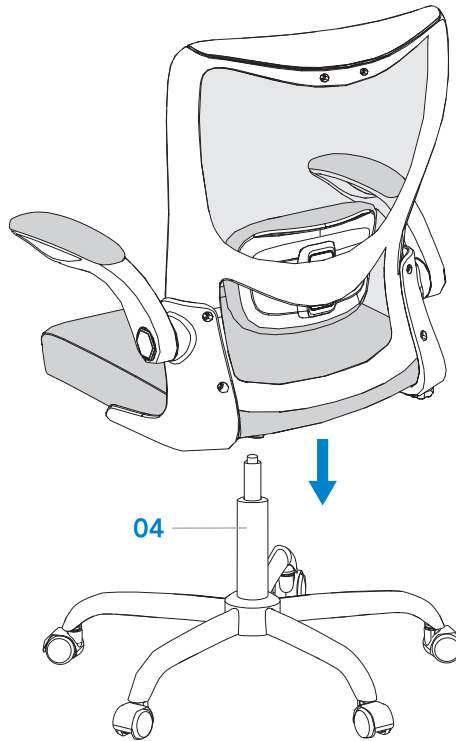

Step 7 Attaching the Headrest

Attach the headrest [10] to the backrest [07] with bolts [D].

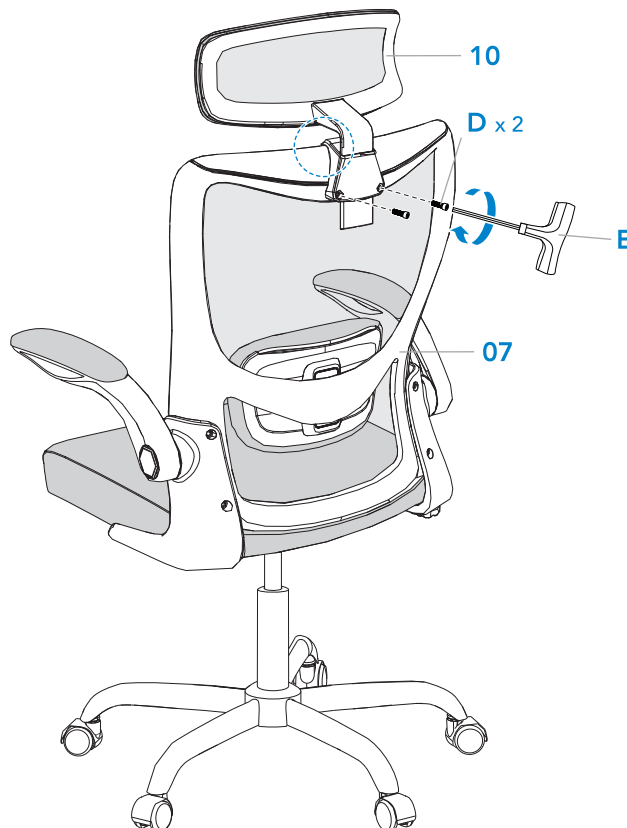
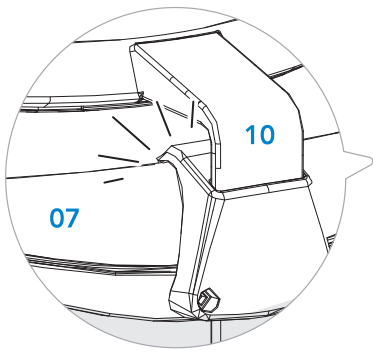

IMPORTANT SAFETY INFORMATION

- Compare package contents to the supplied parts and hardware list to confirm that all parts were received and undamaged. Do not use damaged or defective parts. If you require replacement parts, please email customer service.
- Carefully read all instructions before attempting installation. If you have any questions or concerns, please email customer service.



Only (1) person should sit in the chair at a time.



Only use the chair on level flooring.



Sit correctly in the chair by utilizing the full seat with weight centered over the base.

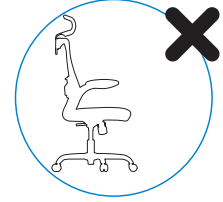

Do not sit on the edge of the chair.

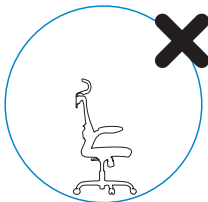

Do not stand on the chair or use it as a ladder or stair.

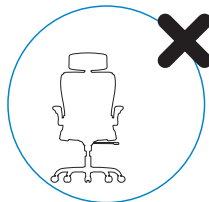

Do not sit on the armrest. Sitting on the armrest can lead to damage and injury.

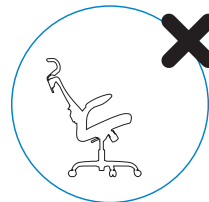

To avoid tipping over, do not lift legs up while tilting the backrest or rocking.



Children under 5 years of age should not operate the chair alone.



Do not put heavy objects on the chair, or use it as a trolley.

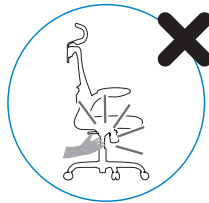

Keep hands away from the seat lift mechanism during operation.

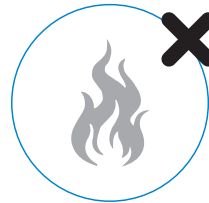

Keep the chair away from flame and heat sources.

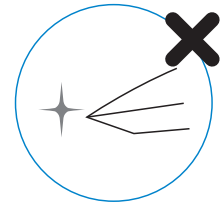

Do not use items with sharp edges or hooks near the chair.

Care and Maintenance

How to Clean

- It is recommended that the office chair be thoroughly cleaned at least once a month to maintain condition and functionality.
- Use a vacuum cleaner to suck up the dirt that may be resting on the seat.
- The casters will stick if not maintained regularly. Brush the casters with water and wipe clean with a damp cloth.
- If dirt solidifies on the surface of the casters, use soap and water to clean it off.
- Use a dry cloth to finish cleaning, or leave your office chair in a ventilated area to air dry.

Maintenance Tips

- Direct sunlight can ruin an office chair over time, degrading most fabrics and materials. Keep your office chair out of direct sunlight.
- Humid conditions may lead to the formation of mildew on fabric and/or rust on metal parts. Do not keep your office chair in a damp environment.
- Be careful with drinks, food, or any type of liquids when you are near your chair. If a spill happens, clean and attend to stains immediately.
- Avoid the use of sharp objects or blades near the office chair that may cause damage.
- If possible, cover the chair to protect it from dirt and dust.
- Regularly examine the chair to ensure that all nuts and bolts are correctly fastened, including those connecting the seat, back, and chair mechanics.

- Retighten bolts every 6 months by using the included Allen key.
- *Using an electric drill can damage the chair. Please use hand tools.

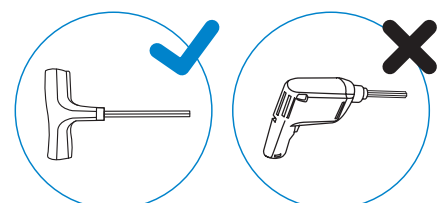

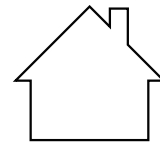
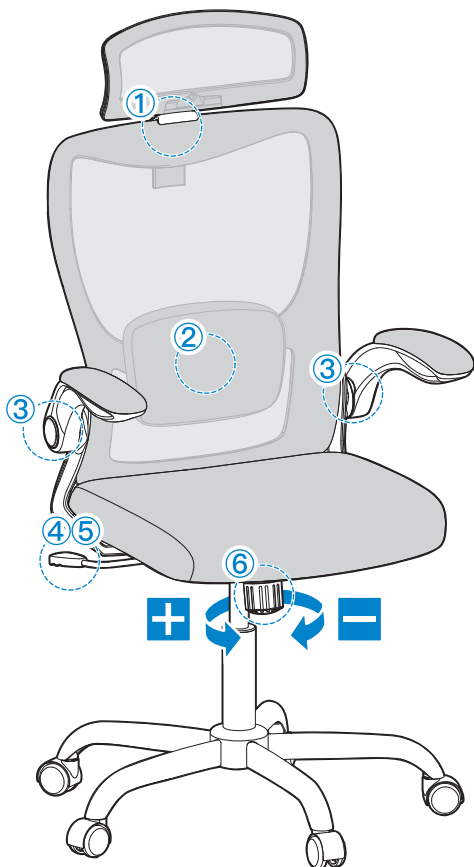

Uso en oficinas domésticas

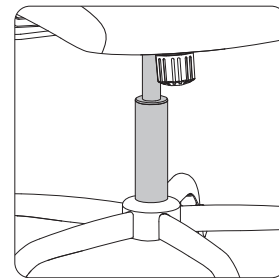

¡ADVERTENCIA! Sólo el personal cualificado puede sustituir o reparar los componentes de regulación de la altura del asiento con acumuladores de energía.

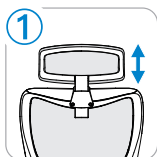

① Ajuste de altura del reposacabezas:

Agarre ambos lados del reposacabezas para ajustar la altura.

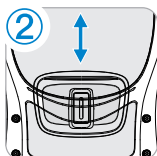

② Ajuste de altura del soporte lumbar:

Agarre ambos lados del soporte para ajustarlo hacia arriba o hacia abajo.

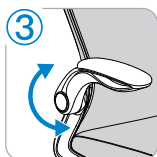

③ Apoyabrazos plegable:

Baje el apoyabrazos para obtener soporte o levántelo cuando no esté en uso.

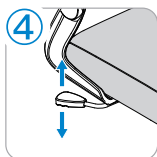

④ Ajuste de la altura del asiento:

Para subir el asiento levante el cuerpo de la silla y tire hacia arriba de la palanca. Para bajar el asiento, descance el cuerpo en la silla y después tire de la palanca hacia arriba.

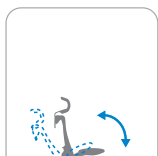

⑤ Función de mecido del respaldo:

Tire hacia afuera de la palanca para habilitar la función de mecido. La silla se mecerá hacia adelante y hacia atrás con el usuario en lugar de quedar bloqueada en una posición fija. Devuelva la palanca a su posición original para bloquearla.

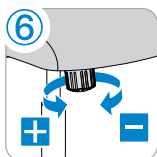

⑥ Ajuste del ángulo de inclinación del respaldo:

Gire la perilla [+] o [-] para aumentar o disminuir la tensión de balanceo.

Consejo: Se puede regular la tensión para que sea compatible con un peso en particular. Aumente la tensión para un peso mayor y disminuya la tensión para un peso menor.

¿Piezas faltantes?

✉ support@huanuo.com

Paso 1 Piezas y herramientas provistas

01 x 5

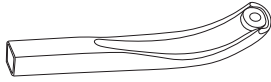

Pata

02 x 1

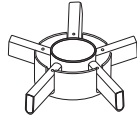

Conector de pata con
tapa decorativa

03 x 5



Rueda

A x 5

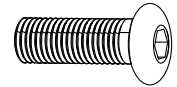

M6 x 15mm
Los Pernos

E x 1

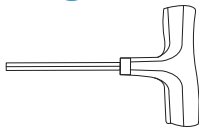

Llave Allen

Paso 2 Piezas y herramientas provistas

04 x 1

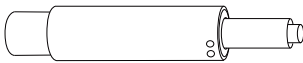

Cilindro Elevador de Gas

Paso 3 Piezas y herramientas provistas

05 x 1

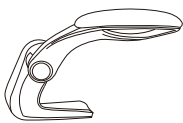

Derecho Apoyabrazo

06 x 1

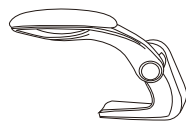

Izquierdo Apoyabrazo

07 x 1



Respaldo

B x 4

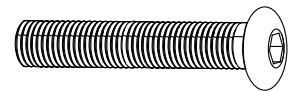

M6 x 30mm
Los Pernos

E x 1

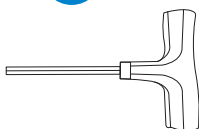

Llave Allen

Paso 4 Piezas y herramientas provistas

08 x 1

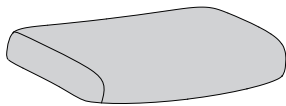

Asiento

B x 4

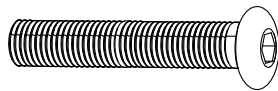

M6 x 30mm
Los Pernos

E x 1

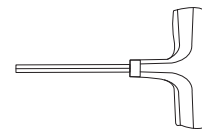

Llave Allen

Paso 5 Piezas y herramientas provistas

09 x 1

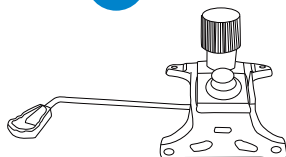

Mecanismo de Elevación

C x 4

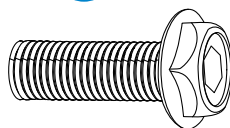

M8 x 20mm
Los Pernos

E x 1

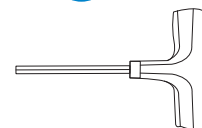

Llave Allen

Paso 7 Piezas y herramientas provistas

10 x 1

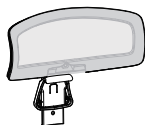

Reposacabezas

D x 2

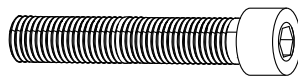

M6 x 30mm
Los Pernos

E x 1

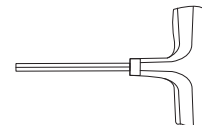

Llave Allen

Paso 1 Montaje de las patas de la silla y la ruedas

Deslice las patas [01] sobre el conector de las patas [02a], luego asegúrelas con los pernos [A].

Retire la cubierta decorativa y guárdela para el Paso 2.

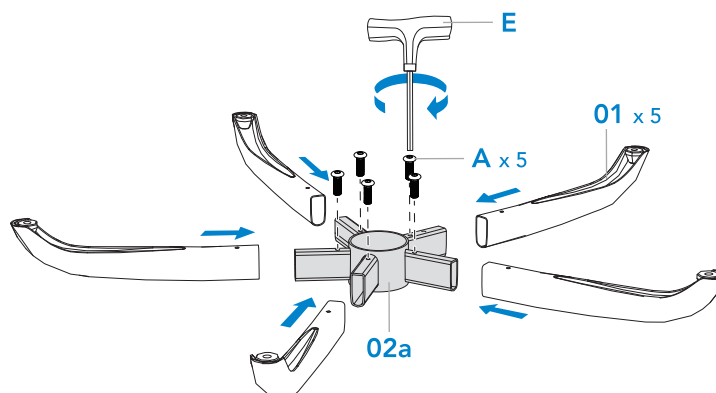
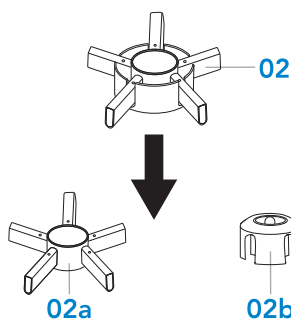

Presione firmemente las ruedas [03] en los agujeros de las patas.

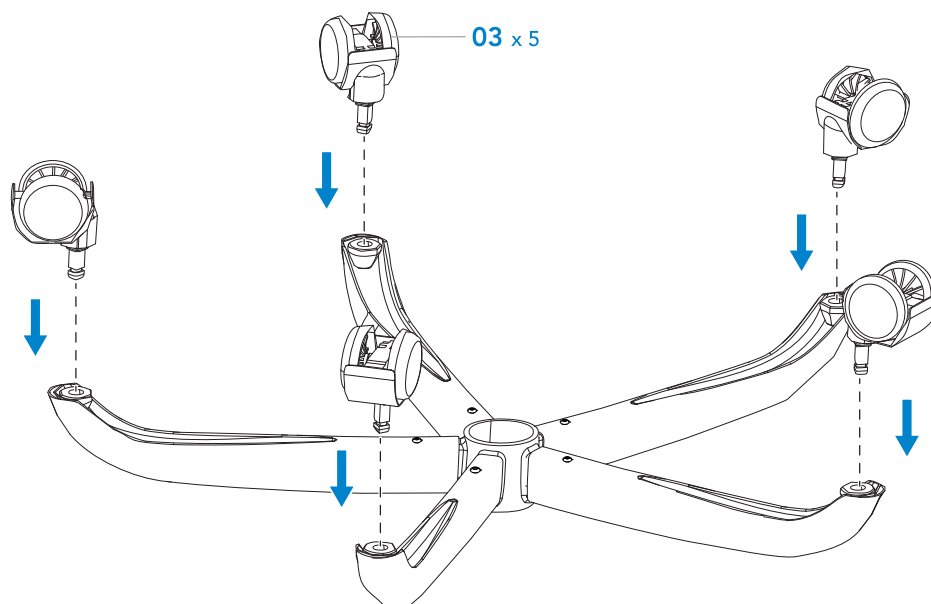

Paso 2 Montaje de la base de la silla

Voltee la base ensamblada. Coloque la cubierta decorativa [02b], luego presione el cilindro de elevación a gas [04] en el conector de la pata.

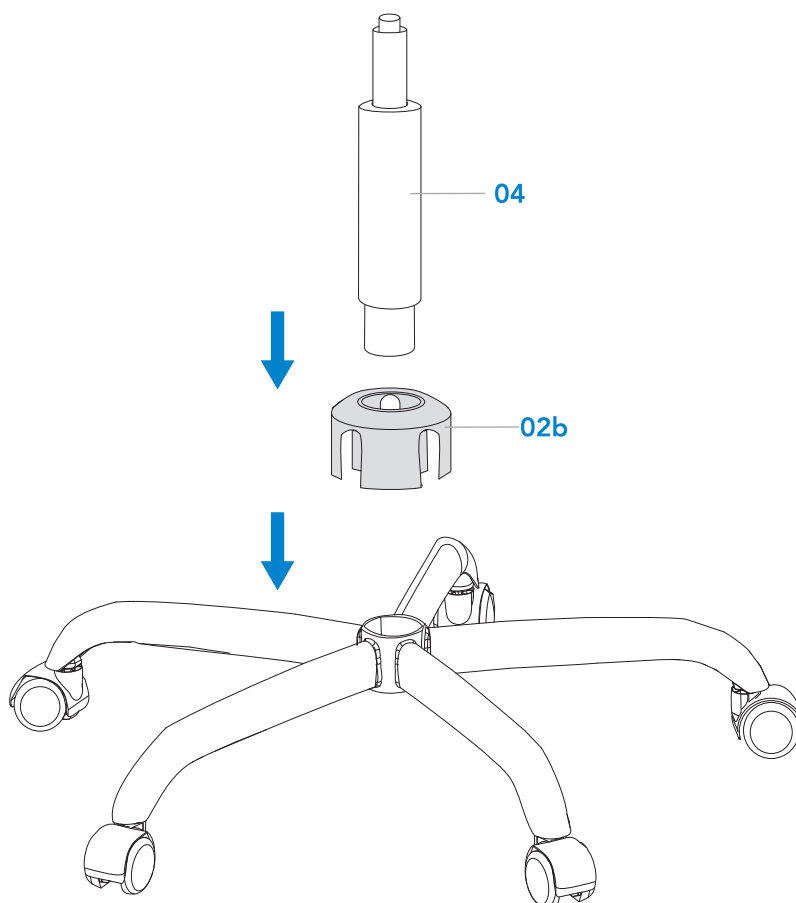

Paso 3 Montaje de los reposabrazos y del respaldo

3-1 Alinee los agujeros del reposabrazos derecho [05] con los agujeros del respaldo [07] y después asegúrelo con pernos [B].

NOTA: Apriete los pernos [B] en los agujeros un 30%. No apriete completamente los pernos [B] hasta que se haya completado el Paso 4.

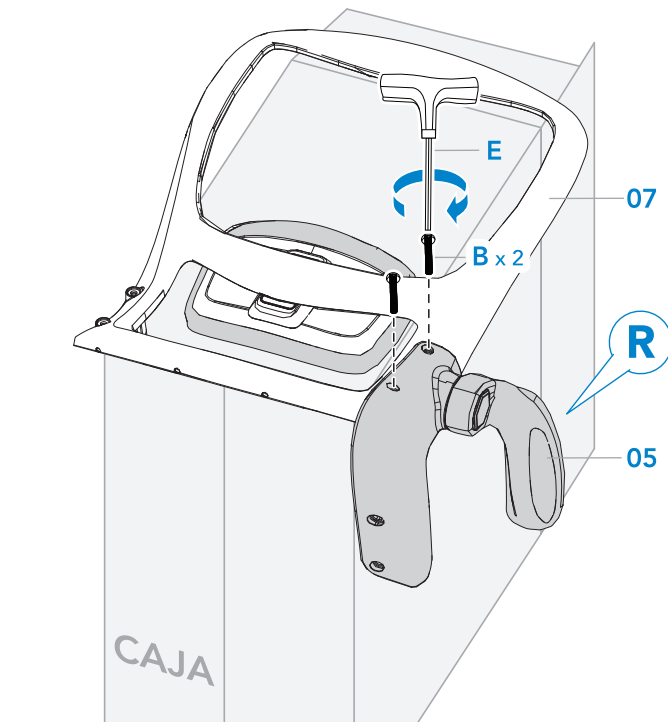

3-2 Dije el otro lado tomando como referencia el Paso 3-1.

NOTA: No apriete completamente los pernos [B] hasta que se haya completado el Paso 4.

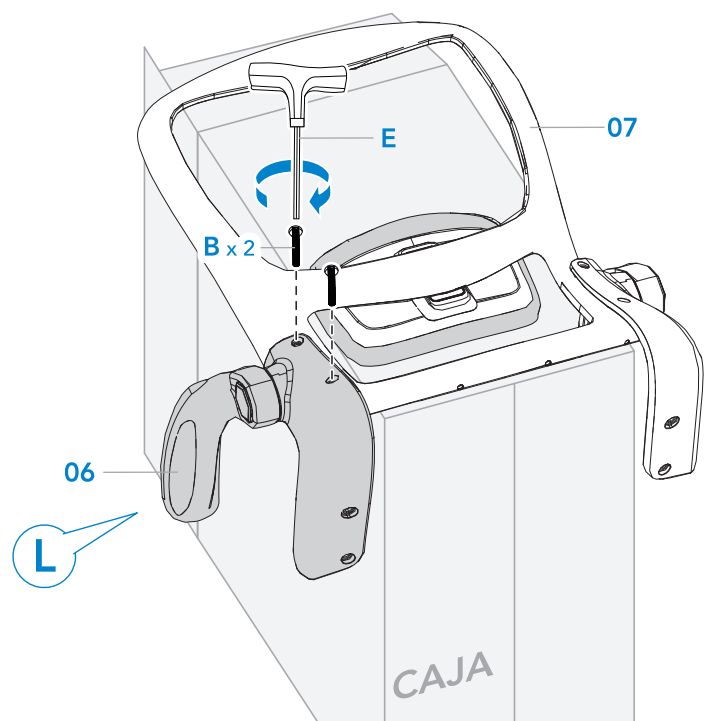

Paso 4 Fijación del asiento

Adjunte el asiento [08] a los reposabrazos ensamblados con pernos [B].
NOTA: Recuerde apretar todos los pernos [B] en este paso.

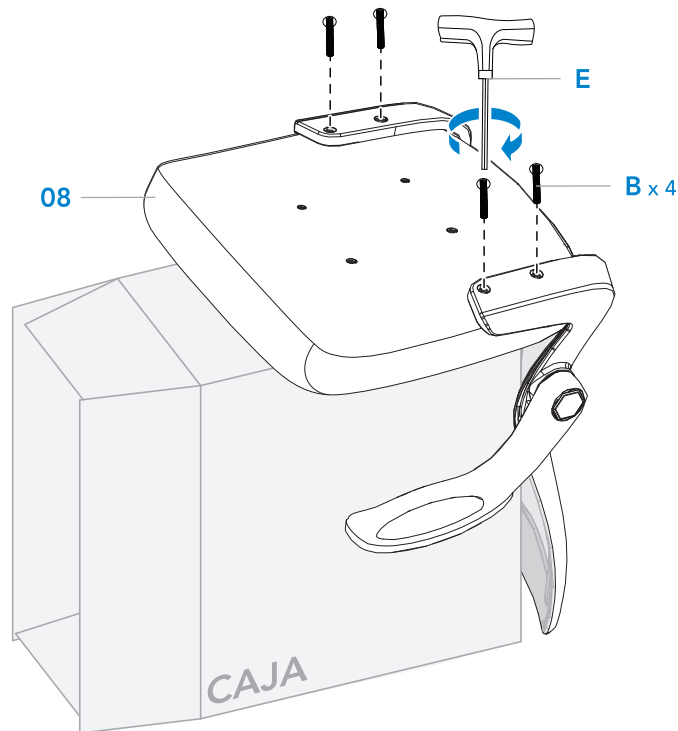

Paso 5 Fijación del mecanismo de elevación

Fije el mecanismo de elevación [09] al asiento [08] con pernos [C].

NOTA:

Tenga en cuenta la posición de la palanca en este paso.

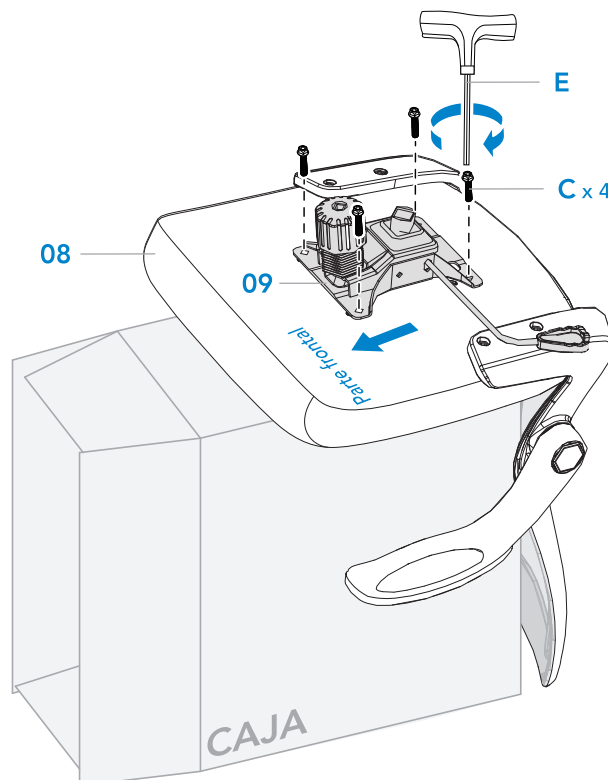

Paso 6 Fijación de la silla a la base

Alinee el agujero situado debajo del cilindro de elevación hidráulico [04]. Presione el asiento hacia abajo para asegurar la silla a la base.



¡OBJETO PESADO!
Es posible que
necesite asistencia en
este paso.

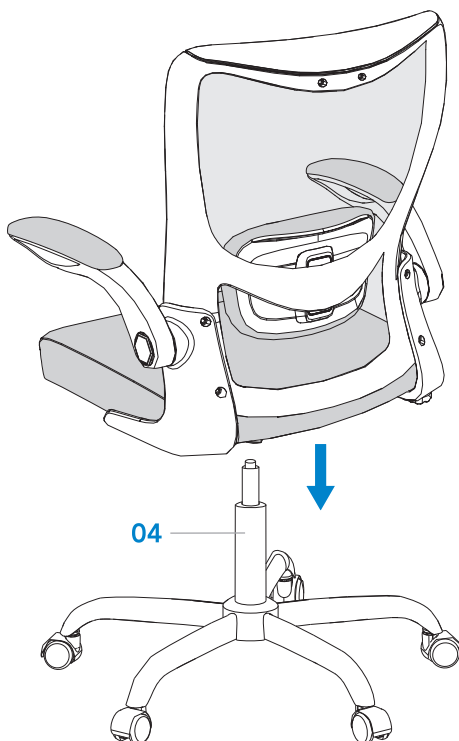

Paso 7 Fijación del reposacabezas

Fije el reposacabezas [10] al respaldo [07] con los pernos [D].

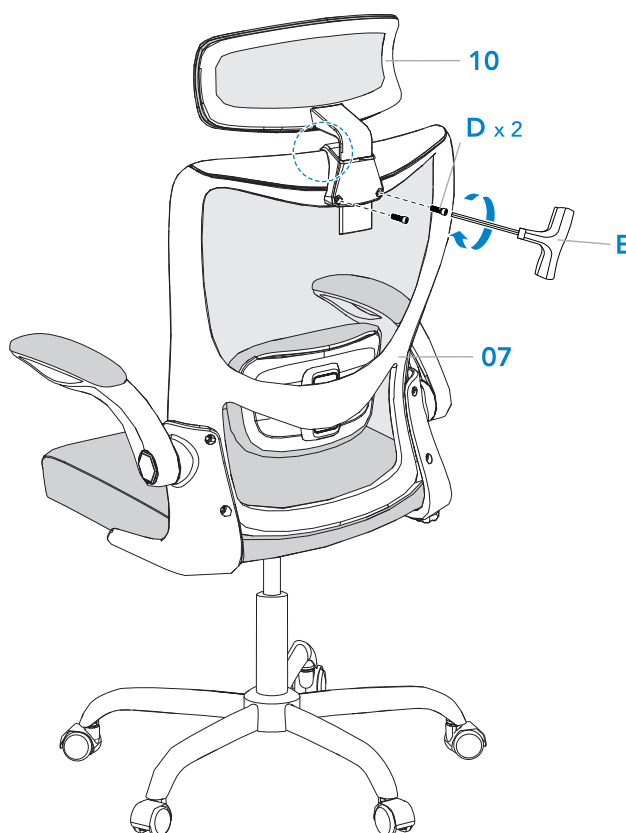
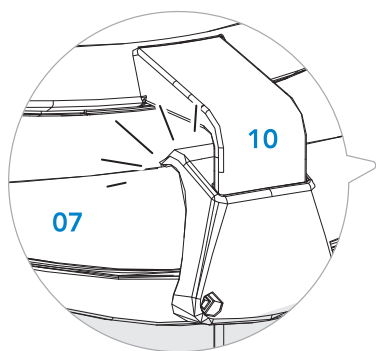

INFORMACIÓN IMPORTANTE DE SEGURIDAD

- Compare los contenidos del paquete en relación con la lista de piezas suministradas y hardware para confirmar que se han recibido todas las piezas y no presentan daños. No use piezas defectuosas o que presenten daños. Si necesita piezas de sustitución, envíe un correo electrónico al servicio de atención al cliente.
- Lea cuidadosamente todas las instrucciones antes instalar. Si tiene alguna consulta o duda, contáctese por correo con nuestro servicio de atención al cliente.



Sólo (1) persona debe sentarse en la silla a la vez.



Utilice la silla sólo en suelos nivelados.



Siéntese correctamente en la silla utilizando todo el asiento con el peso centrado sobre la base.

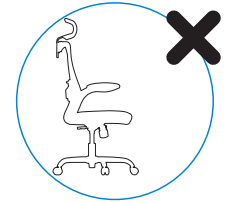

No se siente en el borde de la silla.

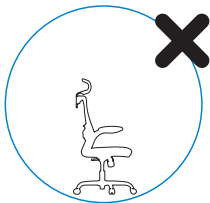

No se suba a la silla ni la utilice como escalera o peldaño.

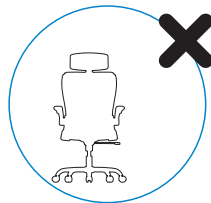

No se siente en el reposabrazos. Sentarse en el reposabrazos puede provocar daños y lesiones.

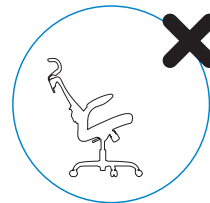

Para evitar volcaduras, no levante las piernas mientras inclina el respaldo o se balancea.



Los niños menores de 5 años no deben utilizar la silla cuando están solos.

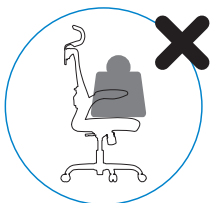

No coloque objetos pesados sobre la silla ni la utilice como carro.



Mantenga las manos alejadas del mecanismo de elevación del asiento durante su funcionamiento.

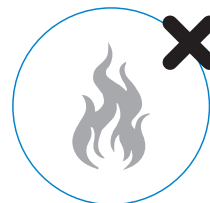

Mantenga la silla alejada de llamas y fuentes de calor.

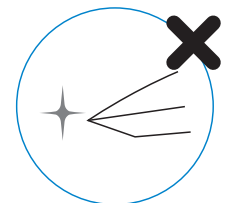

No utilice objetos con bordes afilados o ganchos cerca de la silla.

Cuidado y Mantenimiento

Cómo limpiarla

- Se recomienda limpiar bien la silla de oficina por lo menos una vez al mes para mantener un buen estado y funcionalidad.
- Use una aspiradora para sacar toda la suciedad que se acumule en el asiento.
- Use un paño húmedo para limpiar el apoyabrazos.
- Las ruedas se atorarán si no se les realiza un mantenimiento frecuente. Cepille las ruedas con agua y séquelas con un paño húmedo.
- Puede usar jabón y agua para limpiar cualquier suciedad que se haya solidificado en la superficie de las ruedas.
- Utilice un paño seco para terminar de limpiar o deje la silla de oficina en un lugar ventilado para que se seque al aire.

Consejos de mantenimiento

- La luz solar directa puede arruinar la silla de oficina a lo largo del tiempo, deteriorando las telas y materiales. Mantenga su silla de oficina lejos de la luz solar directa.
- Las condiciones de humedad pueden provocar la formación de moho en el tejido y/u óxido en las piezas metálicas. No guarde la silla de oficina en un ambiente húmedo.
- Tenga cuidado con las bebidas, comida o cualquier otro tipo de líquido cerca de su silla. Si se produce un derrame, limpie y elimine las manchas inmediatamente.
- Evite el uso de objetos afilados o cuchillas cerca de la silla de oficina que puedan causar daños.
- Si es posible, cobra la silla para protegerla de la suciedad y el polvo.
- Revise con frecuencia su silla para asegurarse que todas las tuercas y pernos estén ajustados, incluyendo los del asiento, brazos, y respaldo, así como también los del mecanismo de la silla.
- Vuelva a apretar los pernos cada 6 meses usando la llave Allen que se incluye.
- *El uso de un taladro eléctrico puede dañar la silla. Use herramientas manuales.

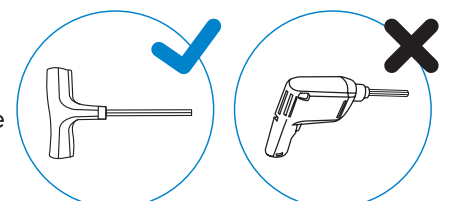

Exceeding Expectations in Office Comfort & Productivity

Superando las expectativas en comodidad y productividad en la oficina

Thank you for choosing this product. We strive to provide you with the best quality products and service in the industry. Should you have any issues, please don't hesitate to contact us.

Gracias por elegir este producto. Nos esforzamos por ofrecerle productos y servicios de la mejor calidad en la industria. Si tiene algún problema, no dude en ponerse en contacto con nosotros.



1-800-556-0533 (US/CA) Mon-Fri, 8am-8pm (CST)

44-808-196-3874 (UK) Mon-Fri, 2pm-10pm (UTC)

 support@huanuo.com



www.huanuo.com

860-00877-00 Rev03